

MG

88

1/4HP

60

HT

N

R000

M001

1

형 번

88	88형
105	105형
105C	105C형
135	135형
153	153형
153105	153과 105의 조합형
172	172형
172105	172와 105의 조합형
181	181형
181135	181과 135의 조합형
181153	181과 153의 조합형
205	205형
205153	205와 153의 조합형
235	235형
270	270형
270172	270과 172의 조합형

비 율

5	1:5
5.5	1:5.5
6	1:6
6.5	1:6.5
6	1:6
7	1:7
7.5	1:7.5
8	1:8
9	1:9
10	1:10
15	1:15
20	1:20
23	1:23
25	1:25
30	1:30
35	1:35
40	1:40
45	1:45
50	1:50
60	1:60
70	1:70
75	1:75
80	1:80
90	1:90
100	1:100
120	1:120
130	1:130
150	1:150
180	1:180
200	1:200
240	1:240
250	1:250
280	1:280
160	1:160
300	1:300
350	1:350
360	1:360
400	1:400
450	1:450
500	1:500
600	1:600
720	1:720
800	1:800
900	1:900
1000	1:1000
1200	1:1200

품질등급

N	일반
D	직거래
S	소음주의
P	파쇄

감속기 옵션

모터 옵션

모터 제조사

케이스타입

HT	수평삼상(Horizontal-T)
VT	수직삼상(Vertical-T)
HS	수평단상(Horizontal-S)
VS	수직단상(Vertical-S)
HL	수평LP(Horizontal-LP)
VL	수직LP(Vertical-LP)

동 력

1/4HP	1/4HP = 0.2kW
1/2HP	1/2HP = 0.4kW
1HP	1HP = 0.75kW
2HP	2HP = 1.5kW
3HP	3HP = 2.2kW
5HP	5HP = 3.7kW
7.5HP	7.5HP = 5.5kW
10HP	10HP = 7.5kW
15HP	15HP = 11kW
20HP	20HP = 15.0kW

MG Duty Table

동력 기어비	0.2kW (1/4HP)	0.4kW (1/2HP)	0.75kW (1HP)	1.5kW (2HP)	2.2kW (3HP)	3.7kW (5HP)	5.5kW (7.5HP)	7.5kW (10HP)	11kW (15HP)	15kW (20HP)	
5											
10			MG135	MG153	MG172		MG172	MG181	MG181	MG205	MG235
20										MG235	
30							MG181	MG205	MG205	MG235	MG270
40											
50	주차기 MG88	주차기 MG105	MG115				MG205	MG235	MG270		
60											
70					주차기						
80			MG153	주차기 MG172	MG181						
90					MG205	MG205			MG270		
100								MG270			
110				MG235		MG235					
120							MG270				
130											
140			MG153 +V105								
150											
200		MG105C		MG181 +V153	MG270 +V172				MG270 +V172		
300			MG181 +V135								
600				MG205 +V153							
900			MG172 +V105								

주1. 입력 회전수 : 1800 rpm 기준
 주2. S.F = 1.0 기준 (1이상을 필요한 경우 연구소에 문의 바랍니다.)

21세기를 선도하는 최고의 기술 최고의 품질

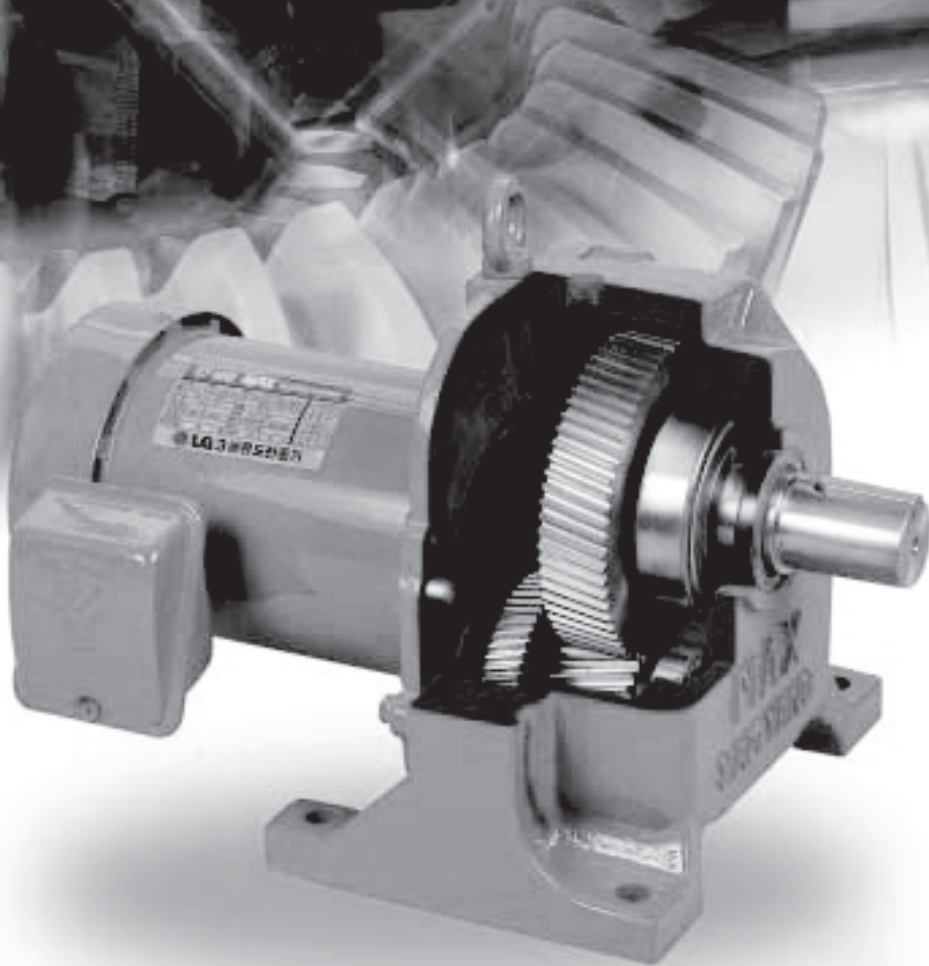

Best Engineered and High Quality MAX leads the 21st Century

■ 특징

◎ 부품 표준화 및 재고 확보

부품 표준화와 사내 재고를 확보 함으로써 최단 납기에 당사 제품을 고객에게 공급하고 있습니다.

◎ 기어드 모터 제품 표준화

최신 설계 기술과 표준화된 부품을 적용하여 반영구적이고 가격 경쟁력 있는 기어드 모터 제품을 생산하고 있습니다.

◎ 고 정밀, 높은 신뢰도의 생산 기술

최신 세이빙, 연마기 등의 장비를 도입하여 고 정밀, 높은 신뢰도의 생산 기술을 실현하고 있습니다.

◎ 소형 & 경량화 설계

소형 경량화 설계 및 특수 열처리와 치형 연마를 적용하여 과부하에 견딜 수 있는 제품을 생산하고 있습니다.

◎ 경제적인 가격

표준화된 대량 생산체제를 갖추므로써 우수한 제품을 경제적인 가격에 공급하고 있습니다.

■ Features

◎ Component Standardization & Securing Stock

We are supplying our geared motors for the customers in the shortest lead time by standardizing its components and securing stock in the company.

◎ Geared Motor Product Standardization

We are providing the reliable and cost-effective geared motors by adopting the leading design technology and its component Standardization.

◎ Highly precise & reliable Manufacturing Technology

We are adapting the highest precise and reliable manufacturing technology with the brand-new shaving machine and grinder.

◎ Compact & Light weighted Product

We are designing the compact and light weighted products and producing it with the specialized heat treatment and saw sharpening, so it can sustain under the overloaded circumstances.

◎ Cost-effective Price

We are providing our products at the cost-effective price while equipping the standardized mass production system.

내부구조도

(Inside Structure)

1. Fan Cover
2. Fan
3. Brake
4. Bearing
5. Motor Bolt
6. Motor Frame
7. Motor Shaft
8. Bearing
9. Oil Seal
10. Eye Bolt
11. Dx Bush
12. Spacer
13. Air Vent
14. Snap Ring
15. Key
16. Gear A
17. Key
18. Output Shaft
19. Oil Seal
20. Bearing
21. Bearing
22. Pinion A
23. Pinion B
24. Bearing
25. Case
26. Gear B
27. Key
28. Snap Ring
29. Key
30. Gear C
31. Hex Bolt
32. Bearing
33. Motor Flange
34. Snap Ring
35. Bearing
36. O-ring

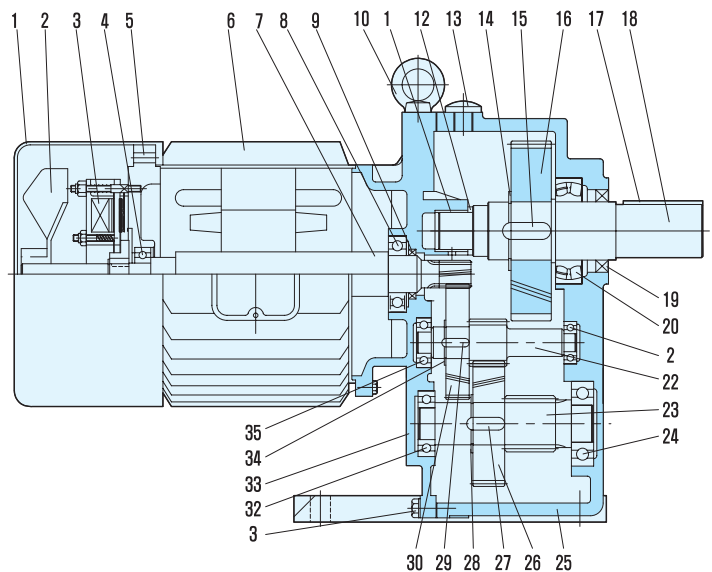
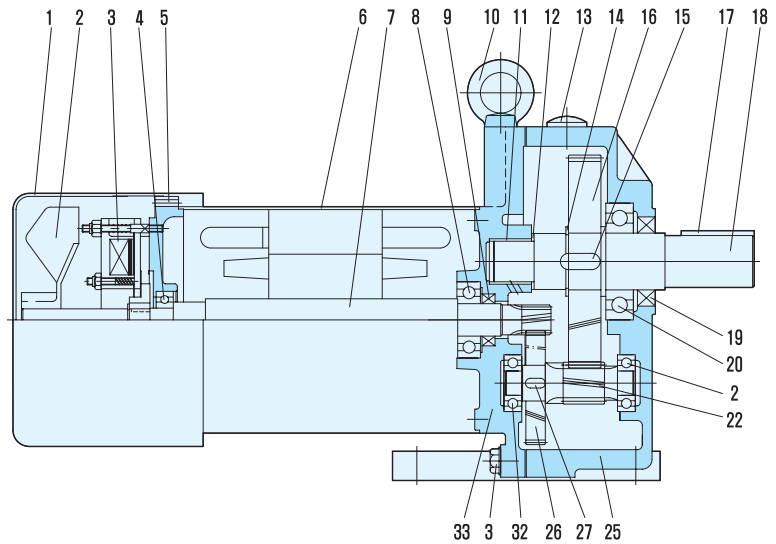
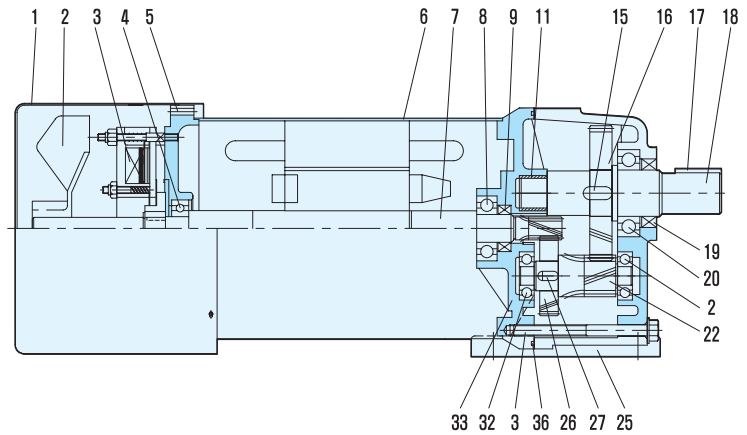

출력의 선정

- ① 필요한 출력축 회전수 N (RPM)에 따라 감속비를 결정하십시오.
- ② 부하 토크 T_1 (kgf-m)에서 전달토크 T(kgf-m)를 산출하십시오.
 $T = T_1 \times Sf$
 Sf (서비스 계수) : 출력축에 작용하는 부하의 성질과 운전시간에 의하여 표1에 표시하였습니다.
- ③ 산출된 전달토크 T(kgf-m) 및 부하 토크 T_1 (kgf-m)과 회전수 N(RPM)에 의하여 그림1의 출력선정도에 의하여 각각의 모터용량을 구하고 가능한 높은 쪽으로 선정하여 주십시오.

- (예) 출력수 회전수 : N = 60RPM (60Hz)
 부하토크 : $T_1 = 20 \text{ kgf-m}$
 피동기 : 콘베어 (균일하중)
 운전시간 : 12시간 / 일
- a. 감속비 $f = 60/1800 = 1/30$
 - b. 전달 토크 T : 표2 및 표1에 의하여 Sf = 1.25
 $T = T_1 \times Sf = 20 \times 1.25 = 25 \text{ (kgf-m)}$
 - c. 모터출력
 부하 토크 T_1 에 의거 N = 60 과 $T_1 = 20$ 의 교차점을 구하십시오.
 교차점은 0.75 Kw와 1.5 Kw의 사이

Power Estimation

- ① According to required output shaft rotation N(RPM), calculate reduction ratio.
- ① Calculate T transfer Load from load torque T_1 (kgf-m) by
 $T = T_1 \times Sf$
 where Sf is service factor, T types of service factor have been classified in T able 1 according
- ③ Using obtained transfer torque T, load torque T_1 and rotation N, choose motor capacity from Fig.
 If possible, choose higher one.

- (EX) Output shaft rotation : N = 60 RPM(60Hz)
 Load torque $T_1 = 20 \text{ kgf-m}$
 Driven Machine : Conveyor
 Operation Hours : 12 Hours/day
- a. Reduction Ratio : $f = 60 / 1800 = 1/30$
 - b. Transfer Torque : T
 $Sf = 1.25$ from T able 2 and T able 1
 $T = T_1 \times Sf = 20 \times 1.25 = 25 \text{ (kgf-m)}$
 - c. Motor Output
 Point the crosspoint of $T_1(=20)$ and $N(=60)$.
 The crosspoint is between 0.75Kw and 1.5 Kw.

U : 균일 하중(Uniform Load)
 M : 中 정도 충격(Medium Impact)
 H : 中 정도 충격(Heavy Impact)

표1. 서비스 계수 Sf(Service Factor Sf)

Operation Hr. / Load	U	M	H
3시간 이하/일 (Less 3Hr/Day)	1	1	1.5
3~10시간/일 (3~10Hr/Day)	1	1.25	1.75
10시간 이상/일 (More than 10Hr/Day)	1.25	1.5	2

표2. 피동기계 부하 분류표(Driven Machine)

피동기계명(Driven Machine)	부하(Load)	피동기계명(Driven Machine)	부하(Load)
송풍기 Air Blower	U	호이스트 Hoist	M
주조 및 증류장치 Distillation	U	공작기계(주기동) Milling Machine(Main)	M
차량 Car	M	공작기계(보조기동) Milling Machine(Sub)	U
클라리 화이어(정제기) Clarifier	U	금속가공기계 Steel Process Machine	H
선별기 Sorter	M	회전밀 Turning Mill	M
요업기계(중부하) Ceramic Machine(M.Load)	M	턴푸라(텀블링 바렐) Tumbling Barrels	H
요업기계(중부하) Ceramic Machine(H.Load)	H	믹서 Mixer	M
압축기 Compressor	M	유압정제기계 Oil Pressure Cleaner	M
콘베아(균일부하) Conveyor(Uniform)	U	제지기계 Paper Machine	M
콘베아(불균일부하) Conveyor(Non-uniform)	M	제재기계 Wood Cutter	H
크레인 Crane	U	펌프 Pump	M
크라샤 Crusher	H	고무기계(중부하) Rubber Machine(M.Load)	M
준설용선박(중부하) Drainage(M.Load)	M	고무기계(중부하) Rubber Machine(H.Load)	H
준설용선박(중부하) Drainage(H.Load)	H	수처리기계(중부하) Water Cleaner(L.Load)	U
엘리베이터 Elevator	U	수처리기계(중부하) Water Cleaner(H.Load)	M
압출기 Extruder	U	스크린(유체) Screen(Oil Based)	U
팬 Fan	U	제당기계 Sugar Machine	M
공급기 Supplier	M	섬유기계 Textile Machine	M
공급기(왕복동식) Supplier(Commuting)	H	제철기계(열간) Iron Works(Heat Treat)	H
식품기계 Food Machine	M	제철기계(냉간) Iron Works(Cold Treat)	U
햄머밀 Hammer Mill	H		

그림 1. 출력 선정도 (Output Estimation Chart)

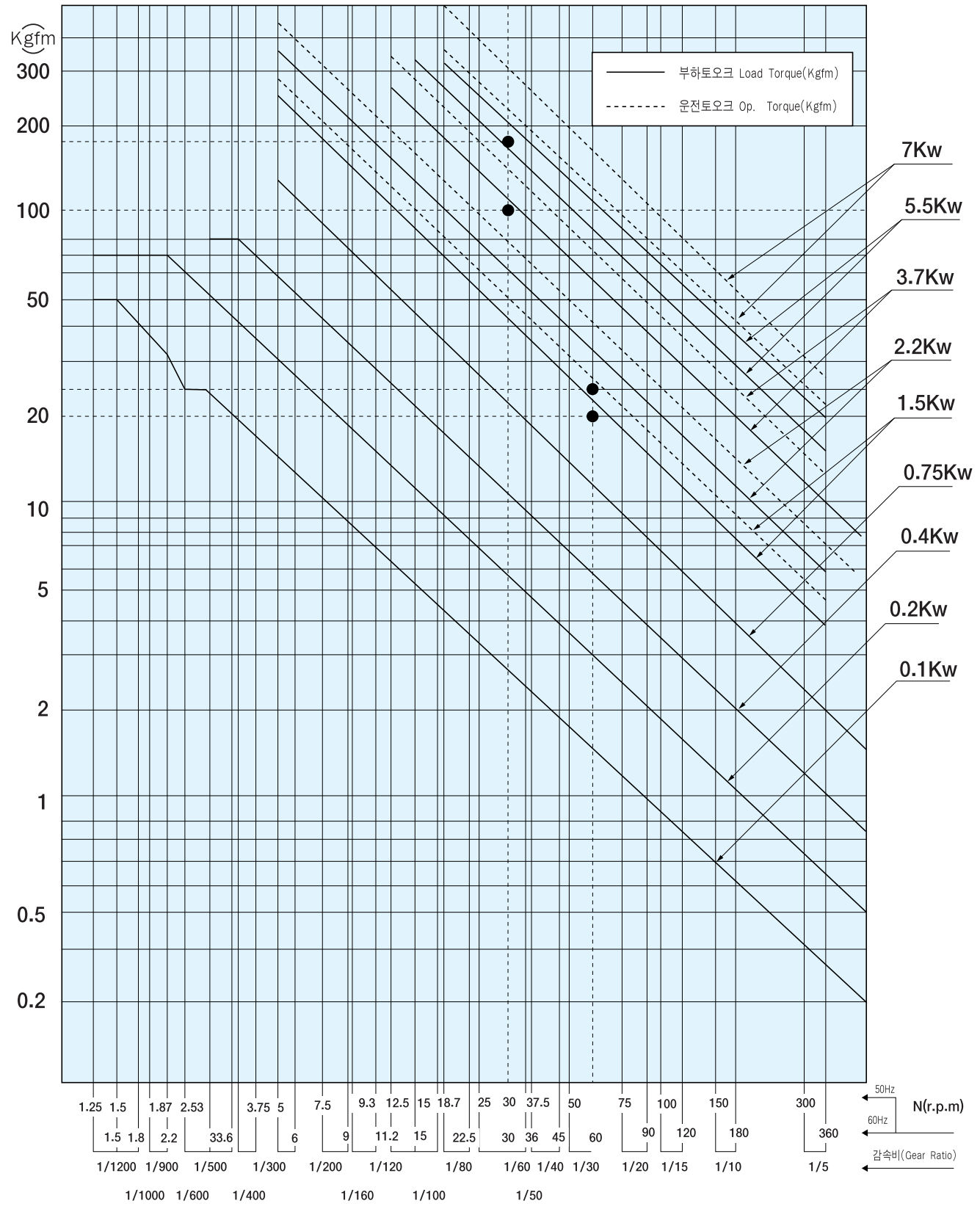

O.H.L.(Overhang Load)의 확인

O.H.L은 출력축에 작용하는 굽힘하중의 위치를 표시하고 있습니다. 상대기계와 체인, 기어, 벨트 등으로 연결한 경우에 발생하며, 카프링에 의한 직결의 경우에는 발생하지 않습니다.

$$O.H.L(kgf) = T_1 / R \times Sf \times Ef \times Lf \times 1000$$

$T_1(kg-m)$: 사용 토크

$R(mm)$: 스프로킷, 기어, 풀리 등의 피치원반경

Ef : 연결방법에 따른 Ef 값 (표3에서 구함)

Lf : 작용거리에 따른 Lf 값 (표4에서 구함)

산출한 O.H.L은 사용 기어드 모터의 허용 O.H.L의 이하에서 R 및 Lf 를 결정하여 주십시오.

허용 O.H.L은 규격별로 표시되어 있습니다.

팔라이 휠 효과

부하의 관성(GD^2)이 크거나 단속운전을 할 때 시동시(또는 브레이크에 의한 제동시)에 간헐적으로 커다란 토크가 발생할 경우에 고장의 원인이 될 수가 있으므로 그림3에 의한 부하의 관성과 허용시동 회수를 확인하여 주십시오.

$$\begin{aligned} &\text{모타축환산부하 } GD^2(GD^2 f) = \\ &\text{출력축환산 } GD^2 \times (\text{속비})^2 \end{aligned}$$

$$GD^2비(R) = \frac{\text{모타축환산부하 } GD^2(GD^2 f)}{\text{기어드모터의 } GD^2(GD^2 m)}$$

$GD^2 m$: (11페이지 참조)

그림 2 (Figure 2)

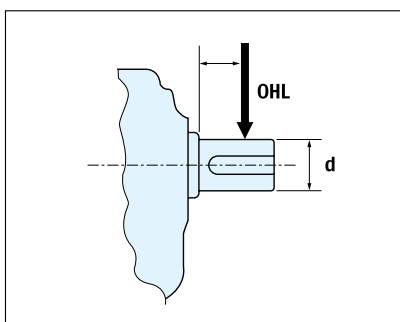

Overhang Load

Overhang load indicates the position of side force occurred on output shaft. Overhang load is typically occurred when the motor has been coupled through chain, gear or belt and so forth. Direct coupling does not cause overhang load.

$$O.H.L(kgf) = T_1 / Sf \times Ef \times Lf \times 1000$$

$T_1(kg-m)$: Applied T or que

$R(mm)$: Diameter of pitch in sprocket, gear or pulley

Ef : Ef value according coupling method (Refer Table 3)

Lf : Lf value according operation distance (Refer Table 4)

Obtained OHL should be lower than allowed OHL of selected gear motor, and R and Lf is obtained from the obtained OHL value. Allowed OHL is enlisted according to types.

Fly Wheel Effect

When load inertia(GD^2) is high or the motor is intermittently operated, momentarily occurred heavy torque may cause the reason of breakdown. Please make sure of load inertia and allowable starting number from Picture 3.

$$\text{Motor Shaft Conversion Load Inertia } (GD^2 f) =$$

Output Shaft Conversion Inertia x

(Reduction Ratio)² where,

$$\text{Inertia Ratio}(R) = \text{Motor Shaft Conversion Load Inertia } (GD^2 f) / \text{Geared Motor Inertia } (GD^2 m)$$

For $GD^2 m$, refer data table in page 11.

Using obtained R and Figure 3, one can get allowable starting total number.

표3. 연결방법(Coupling Ef)

단열체인 (single Row Chain)	1.00
타이밍 벨트 (Timing Belt)	1.00
복열체인 (Double Row Chain)	1.25
기어 (Gear)	1.25
벨트 (V-Belt)	1.50
평벨트 (Plain Belt)	2.50

R 수치와 그림3에 의한 허용시동시 총회수를 얻을 수 있습니다.

(예) 모터출력 : 5.5kw 연결방법 : 체인
 속 비 : 1/10 기동정도 : 20 sw/h
 부하 GD²(출력축환산) : 4.8 kg · m²

- 1) $GD^2 f = 4.8 \times (1/10)^2 = 0.048 \text{Kg} \cdot \text{m}^2$
- 2) $R = \frac{GD^2 f}{GD^2} = \frac{0.048}{0.12} = 0.4$
- 3) 그림3에 의한 R = 0.4 의 수직선 체인의 선과 교점을 구하고 그점에 의한 수평선과 5.5kw 선의 교점이 허용시동 총회수로 3 × 10⁵ 회수가 됩니다.
- 4) 내구시간은 $\frac{\text{허용시동총회수}}{\text{기동정도}} = \frac{3 \times 10^5}{20} = 15,000 \text{시간}$

표4. 작용위치(Applied Point Lf)

f	Lf
0.25d	0.85
0.50d	0.90
0.75d	0.95
1.00d	1.00
1.25d	1.25
1.25d	1.50

(EX)

Motor Output : 5.5 kw, Reduction Ratio : 1/10
 Load Inertia(Output shaft Conversion) : 4.8Kg · m²
 Coupling Method : Chain, Starting Coefficient : 29sw/h

- 1) $GD^2 f = 4.8 \times (1/10)^2 = 0.048 \text{Kg} \cdot \text{m}^2$
- 2) $R = \frac{GD^2 f}{GD^2} = \frac{0.048}{0.12} = 0.4$
- 3) In Picture 3, find the crosspoint(A) of R = 0.5 and the curve of chain. Then the allowable starting total number is the crosspoint between horizontal line from(A) and the required power 5.5 K w.In this becomes 3 × 10⁶.
- 4) Durable hours : Allowable starting total number / Starting Coefficient = 3 × 10⁵/20 = 15,000 hours

그림 3 허용시동 총회수(Allowable Starting Total No.)

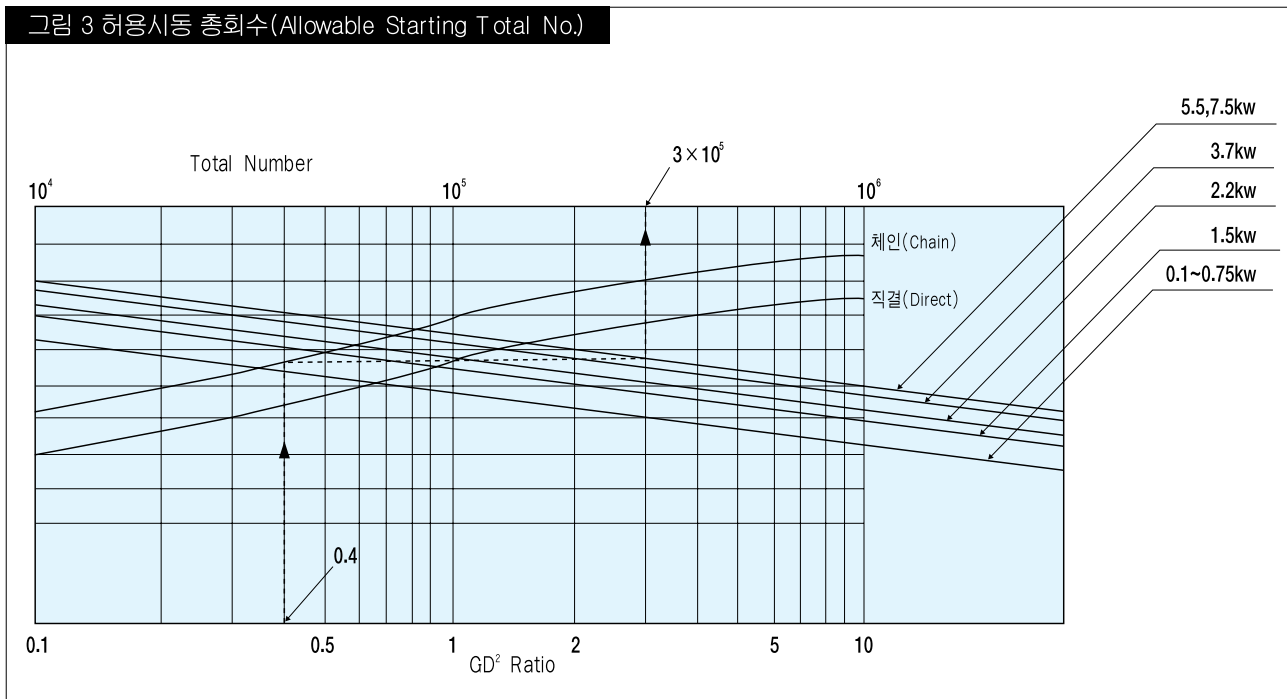

기어드 모터 형식별 설치방향

형 식	윤 활	H 형	V 형
MAX-H 3상	그리스	수평형 (어떠한 방향으로도 설치가능) 	플랜지형
MAX-H 단상	그리스	(그림과 같은 방향으로 설치 가능) 	

- 그리스 윤활의 경우는 위와 같이 자유로히 설치할 수 있음.
- 브레이크 부착형 기어드 모터의 경우 세워서 설치할 경우 슬립발생을 주의

GEARED MOTOR INSTALLATION

Type	Lubricant	H Type	V Type
MAX-H 3-Phase	Grease	Horizontal (Any Direction Installable) 	Flange
MAX-H 1-Phase	Grease	 (Specified Direction Only)	

- Grease charged motor can be installed for any direction.
- Caution is necessary for geared motor with brake to be installed vertically in order to prevent slip.

기어드 모터 규격별 그리이스 및 오일 주입량 (Grease or Oil Charging Quantity)

	1/5	1/10	1/15	1/20	1/30	1/40	1/45	1/50	1/60	1/80	1/100	1/120	1/160	1/200		
0.2 Kw	0.1					0.42	-	0.42					0.7			Grease
0.4 Kw	0.1		0.3			0.7					1.5					
0.75 Kw	0.45				0.55	1.0								OIL		
1.5 Kw	0.9		1.0		1.4	2.0										
2.2 Kw	1.0		1.4		1.9	2.5										
3.7 Kw	1.9				2.3	3.8										
5.5 Kw	2.3				3.6	4.5										
7.5 Kw	2.3			3.6	4.3	7.0										

- 0.75kw VERTICAL Geared Motor에는 Grease윤활
- 공장 출하시에 0.2 ~ 0.4 Kw의 전기종에 그리이스를 0.75 ~ 7.5Kw 전기종에는 오일을 충전하여 출하하고 있습니다.
- 그리이스의 교환시기는 10,000시간마다 교환하여 주십시오.
- 오일의 교환시기는 500시간 가동 후 1회 교환 후 매 2,000시간 마다 교환하여 주십시오.
- 그리이스 및 오일 교환시 양은 상기표를 참조 하십시오.
- Geared motors powered between 0.2 and 0.4 Kw are charged with grease during factory shipment. Also, geared motor powered between 0.75 and 7.5 Kw are charged with oil.
- Grease should be re-charged at every 10,000 hours.
- Oil needs to be changed first 500 hours operation, and hereafter to be changed at every 2,000 hours.

기어드 모터의 GD_M(모터축 환산)

Geared Motor GD_M (Motor Shaft Conversion)

Kw	4P	
	일반형 General	브레이크 부착 With Brake
0.4	0.0056	0.0069
0.75	0.0099	0.0112
1.5	0.0271	0.0321
2.2	0.0301	0.0351
3.7	0.0456	0.0967
5.5	0.0633	0.114
7.5	0.106	0.167

MAX-GM 소음 수준

MAX Geared Motor Noise Level

Geared Ratio	1/120	1/90	1/60	1/45	1/30	1/20	1/15	1/10	1/5
RPM	15	20	30	40	50	90	120	180	360
출력 (Kw)	0.4	62	62	62	62	62	62	62	62
	0.75	65	65	65	65	65	66	66	66
	1.5	70	70	70	70	70	70	71	71
Output	2.2	70	72	72	72	72	72	72	72
	3.7	70	72	72	72	72	72	72	72
	5.5	72	72	72	72	72	72	72	72
	7.5		74	73	73	74	75	75	74

삼상유도 전동기 참고 특성 DATA

Three Phase Induction Motor Reference Characteristic Data

출력 KW(HP)	극수 Pole	정격전류 Regular Current		기동전류 Starting Current		효율 Efficiency %	역율 Power Factor %	전부하 Total Load Torque(Kg-m)	Slip %	R.P.M
		220V	380V	220V	380V					
0.4 (1/2)	2	2.4	1.4	17.4	10	62.0	72		8.5	3294
	4	2.6	1.5	16.4	9.5	63.5	63		9.0	1638
	6	3.0	1.7	19	11	62.0	55		10	1080
0.75 (1)	2	3.6	2.1	28	16	68.0	77		7.5	3330
	4	3.8	2.2	25	15	69.5	70	0.42	8.0	1656
	6	4.4	2.5	29	17	63.0	63	0.65	8.5	1098
1.5 (1½)	2	4.4	2.5	34	20	71.5	79		7.0	3348
	4	4.6	2.6	30	17	72.0	73		7.5	1665
	6	5.2	3	33	19	71.5	66		8.0	1104
1.5 (2)	2	6.4	3.7	49	28	74.5	81		7.0	3348
	4	9.2	5.3	60	35	78.5	77	1.24	7.0	1674
	6	7.4	4.3	48	28	74.5	69	1.3	8.0	1104
2.2 (3)	2	8.3	5.1	68	39	77.0	81		6.5	3366
	4	9.2	5.3	60	35	78.5	77	1.24	7.0	1674
	6	10.4	6.0	66	38	77.0	71	1.91	7.0	1116
3.7 (5)	2	14	8.1	109	63	80.0	82		6.0	3384
	4	14.6	8.4	100	58	81.0	78	2.09	6.5	1683
	6	15.8	9.1	104	60	80.0	73	3.16	6.5	1122
5.5 (7½)	2	21	12	159	92	82.0	79		6.0	3384
	4	21.8	12.6	150	87	82.5	77	3.09	6.0	1692
	6	23.6	13.6	154	89	82.0	72	4.65	6.0	1128
7.5 (10)	2	28.2	16.3	209	121	83.0	80		6.0	3384
	4	29.2	16.8	191	110	83.5	78	4.2	6.0	1692
	6	31	17.9	205	118	83.0	73	6.3	6.0	1128

단상유도 전동기 참고 특성 DATA

Single Phase Induction Motor Reference Characteristic Data

형식 Type	극수 Pole	출력 Output (KW)	프레임 Frame No.	전압 Voltage (V)	전부하 Total Load			기동 Starting		최대토크 Max. Torque(%)	효율 Efficiency (%)	컨덴서 Condenser Capa.(µF)
					Torque (kg · m)	전류 Current(A)	R.P.M	Torque (%)	전류 Current(A)			
EOUP	4	0.1	71	110	0.056	2.8/1.4	1750	260	15.0/7.5	260	51	100
		0.2	71		0.112	5.6/2.8	1750	260	23/11.5	260	55	180
		0.25	71		0.139	6.4/3.2	1745	260	29/15	260	58	200
		0.3	71		0.167	7.2/3.6	1740	260	33/17	260	60	200
		0.4	90		0.222	8.7/4.4	1750	265	38/19	250	59	200

특징

- a) 무여자 작동형 (스프링 크로스식)으로서 정전시에는 자동적으로 작동하는 안전 브레이크입니다.
- b) 전원장치가 있어 배선이 용이합니다.
- c) 간단한 구조로 브레이크 갭 조정도 용이합니다.

Features

- a) Cross spring type geared motor is automatically operational event at power fallure.
- b) Power connector makes easy wiring.
- c) Simple structure makes brake gap adjustment easy.

브레이크사양 Brake specification

사양 Spec.	출력 Output(KW) 4p	0.1	0.2	0.4	0.75	1.5	2.2	3.7	5.5	7.5
	브레이크 Brake		SB-02	SB-1.0	SB-1.0	SB-2.0	SB-3.0	SB-6.0	SB-8.0	SB-8.0X2
토크 Torque (kg · m)		0.2	1.0	1.0	2.0	3.0	3.5	8	12	15
전원장치 Power Supplier		HD-10	HD-20B							
전압 Voltage		AC 220V (DC90V)								
전류 Current at 75°C (A)		0.082	0.27	0.27	0.25	0.27	0.3	0.4	0.4	0.56
용량 Capacity at 75°C(W)		7.3	24	24	22	24	27	36	36	50
규정 틈새 Regular Gap (mm)		0.2	0.3					0.4		
한계 틈새 Limit Gap (mm)		0.8	0.8					1.5		
허용별 열발산량 Allowable Heat Dissipation at 1500R.P.M 50% ED(kgf.m/min)		100	500	500	600	800	800	1100	1100	1100
총사사양 E.T (kgf · m)		9 X 10 ⁵	2.2 X 10 ⁷	2.2 X 10 ⁷	3.6 X 10 ⁷	4.5 X 10 ⁷	4.5 X 10 ⁷	6.3 X 10 ⁷	8.4 X 10 ⁷	8.4 X 10 ⁷
개방시간 Amateur Release Time(sec)	동시절환 AC/DC Converting	0.3	0.225	0.205	0.298	0.150	0.135	0.230	1.20	1.20
	교류절환 AC Converting	0.17	0.130	0.075	0.120	0.054	0.050	0.070	0.50	0.45
	직류절환 DC Converting	-	0.023	0.012	0.013	-	-	-	0.075	0.065

브레이크의 구조

Brake Structure

SB-1.0 ~ 8.0

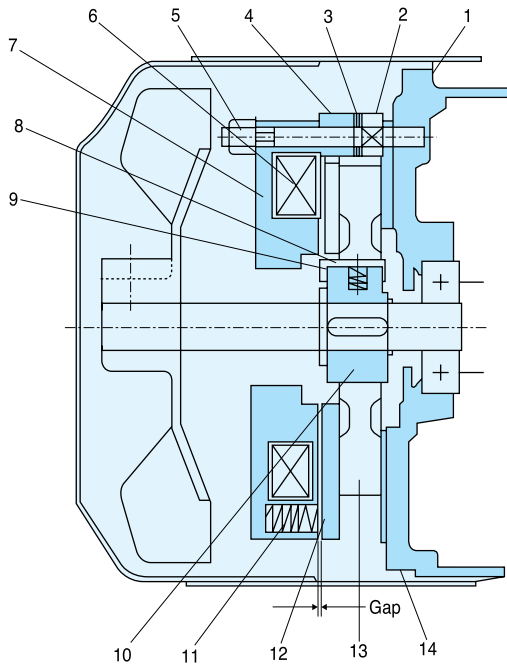

SB-0.2

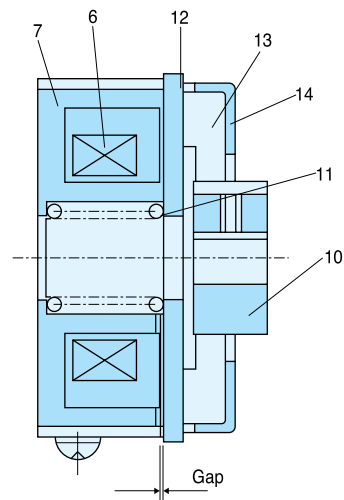

No.	명 칭	Name
1	브라켓 실드	Bracket shield
2	스터드 볼트	Stud Bolt
3	어드져스트 라이너	Adjust Liner
4	칼라	Collar
5	육각 너트	Hex - Nut
6	코일	Coil
7	자석	Magnet
8	소음 브라켓	Sound Bracket
9	소음 스프링	Sound Spring
10	호브	Hob
11	브레이크 스프링	Brake Spring
12	아마추어	Armature
13	내부 디스크	Inner Disk
14	브라켓	Bracket

GD²플라이 휠의 효과 계산법 Calculation of Fly Wheel Inertia GD²

관성을 일반적인 관성모멘트 J (Kg · m · sec²)로 나타내고 있습니다만 공업용으로 실제 사용할 경우는 GD²(kg-m²)을 사용하는 것이 편리하다.

In general, inertia is represented by inertia momentum (kg.m.sec²), however, GD² is more widely used for industrial purpose.

$$GD^2 = 4gJ \quad \text{여기서} \quad \left\{ \begin{array}{l} G \dots \dots \text{중량 Weight (Kg)} \\ D \dots \dots \text{회전직경 Rotation Diameter (m)} \\ g \dots \dots \text{중력가속도 Gravity (9.8m/sec}^2\text{)} \\ J \dots \dots \text{관성모멘트 Inertia Momentum (kg.m.sec}^2\text{)} \end{array} \right.$$

회전체의 GD² Inertia of Gyration Object

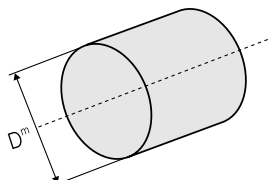
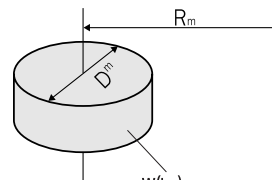
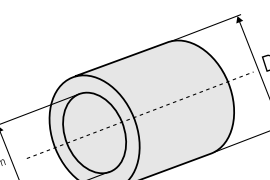
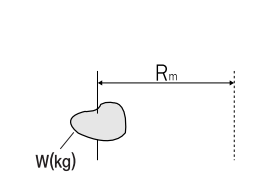
회전중심이 무게중심과 일치할 때 Rotation Center = Gravity Center		회전중심이 무게중심과 일치하지 않을 때 Rotation Center ≠ Gravity Center	
 <p style="text-align: center;">W(kg)</p>	$GD^2 = \frac{1}{2} WD_m^2$ (Kg · m ²)		$GD^2 = \frac{1}{2} WD_m^2 + 4WR_m^2$ (Kg · m ²)
 <p style="text-align: center;">W(kg)</p>	$GD^2 = \frac{1}{2} W(D_m^2 + d_m^2)$ (Kg · m ²)		$GD^2 = 4WR_m^2$ (Kg · m ²)

직선운동을 하는 경우의 GD²

Inertia of Straightly Moving Object

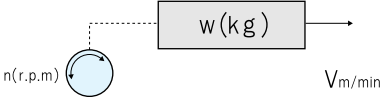
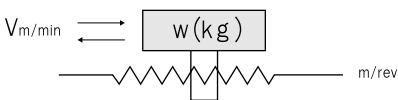
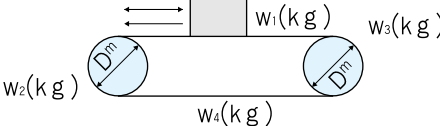
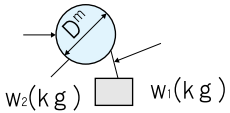
<p>일반적인 경우 General Case</p>		$GD^2 = W \cdot \left(\frac{V}{\pi n} \right)^2$ <p style="text-align: right;">(K g . m²)</p>
<p>수평직선 운동인 경우 Horizontal Straight Movement (리드스크류에 의한 물체의 이동) (Moved by Lead Screw)</p>		$GD^2 = W \cdot \left(\frac{P}{\pi} \right)^2$ $= W \cdot \left(\frac{V}{\pi n} \right)^2$ <p style="text-align: right;">(K g . m²)</p>
<p>수평직선 운동인 경우 Horizontal Straight Movement (콘베어 등) (Conveyor...)</p>		$GD^2 = W_1 D_m^2 + \frac{1}{2} W_2 D_m^2$ $+ \frac{1}{2} W_3 D_m^2 + W_4 D_m^2$ <p style="text-align: right;">(K g . m²)</p>
<p>수직 운동인 경우 Vertical Straight Movement (크레인, 윈치 등) (Crane, Winch...)</p>		$GD^2 = W_1 D_m^2 + \frac{1}{2} W_2 D_m^2$ <p style="text-align: right;">(K g . m²)</p>

회전비가 있는 경우의 GD²

Inertia with Rotation Ratio

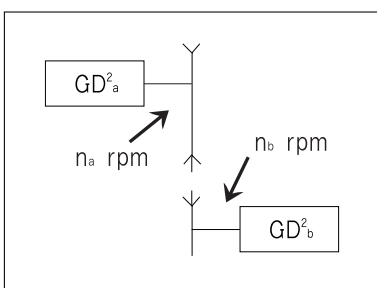

부하축의 GD²_b를 n_a축에 환산할 경우
Conversion of load shaft inertia to n_a shaft

$$GD^2 = GD_a^2 + (n_b/n_a)^2 GD_b^2$$

설치 및 사용상 주의사항

1. 설치전의 점검

감속기는 당공장서 철저한 검사 및 점검한 후 납품하지만, 수송 도중 진동이나 그 외 악영향을 받는 경우가 있으므로 설치 전에 반드시 다음 사항을 점검하십시오.

① 누유되는 곳은 없는가 ② 파손된 부분은 없는가 ③ 명판은 주문 사항과 일치하는가

2. 상대기계와 연결 방식

1) 직결방식

입출력축 모두 직결방식을 사용하는 것이 가장 좋으며 커플링은 가급적 가요성 커플링을 사용하시기 바랍니다.

2) 기어, 체인 스프로켓 사용시

· 입출력축에 체인, 스프로켓, 풀리 등을 취부하는 경우 아래의 공식에 의해서 스프로켓 및 기어의 직경을 선정해 주십시오.
체인스프로켓 기어의 피치원 직경 $\geq 3 \times$ 입출력축의 직경

· 입출력축의 선단에 하중이 작용하면 축에 무리한 힘이 걸려서 축이 파괴되거나 베어링이 손상될 우려가 있으므로 완전히 안쪽(카바쪽)으로 조립한 후 사용하십시오.

3. 윤활유의 선정 및 보존

1) 주유 및 유량

윤활유는 반드시 추천 윤활유를 사용하고 유량은 완전 정지상태에서 유면계의 중심까지 오게 하십시오. 윤활유가 너무 많거나 적으면 기어와 베어링에 악영향을 미칠 우려가 있습니다.

2) 윤활유의 교환

처음 가동시에는 기어의 초기 마모분이 기름에 떨어지므로 운전개시 후 500시간 정도 사용후 새로운 윤활유로 교환하여 윤활유 교환시 내부를 깨끗하게 세척하여 마모분을 제거하십시오.

Cautions during Installation and Use

1. Before Installation

Products get through inspection prior to shipment, however, vibration during delivery or other improper treatment may cause problem. Please make sure of following check point prior to installation.

2. Coupling Method with Machine

(1) Direct Coupling : Direct coupling is the best for both input and output shaft coupling.

(2) Use with Gear, Sprocket or Chain

· When gear, sprocket or chain is connected with input or output shaft, please determine the diameter of sprocket or gear using following equation.

· If load is given to shaft end, excessive force harms to bearing and other parts. Make sure of coupling machine to deep side of shaft.

3. No Load Operation

After 6 hour no load run, actual load running is recommended.

4. Grease

(1) Charging and Quantity : One should use only recommended grease, and charge grease up to the center of oil gauge at fully stoped mode. Both more and less grease may cause problems to gear and bearing.

(2) Grease Change : For the first 500 hour run, there are excessive particles in grease. Hereafter, grease can be replaced at every 2,000 hours. Rinse inside to remove particles during grease change.

(3) Grease Type : The grease types used for standard geared motor are Ks m 2127, ISO VG 150(10c below and ISO VG 220(10c up). Local manufacturers are enlisted below.

추천 윤활유

Recommended Lubricant

Type	Maker	호남정유 Honam Ref. CALTEX	유 공 Yukong GULF	극 동 Kuk Dong SHELL	MOBIL KOREA
ISO VG 68		Meropa Lubricant 68	EP LUBRICANT HD 68	Omala 68	Mobil gear 626
ISO VG 100		Meropa Lubricant 100	EP LUBRICANT HD 100	Omala 100	Mobil gear 627
ISO VG 150		Meropa Lubricant 150	EP LUBRICANT HD 150	Omala 150	Mobil gear 629
ISO VG 220		Meropa Lubricant 220	EP LUBRICANT HD 220	Omala 220	Mobil gear 630
ISO VG 320		Meropa Lubricant 320	EP LUBRICANT HD 320	Omala 320	Mobil gear 632
ISO VG 460		Meropa Lubricant 460	EP LUBRICANT HD 460	Omala 460	Mobil gear 634
ISO VG 680		Meropa Lubricant 680	EP LUBRICANT HD 680	Omala 680	Mobil gear 636
Grease 그리스	NLGI 0	Multifak EP 0	Crown EP 0	Alvania EP 0	Mobilplex EP 0
	NLGI 1	Multifak EP 1	Crown EP 1	Alvania EP 1	Mobilplex EP 1
	NLGI 2	Multifak EP 2	Crown EP 1	Alvania EP 2	Mobilplex EP 2

사용 윤활유

제품종류	하중상태	주위온도	사용윤활유	비고
유성 감속기 기어드 모터	정하중	10°C 이하	ISO VG 150	
		10°C 이상	ISO VG 220	
웜	보통하중	10°C 이하	ISO VG 220	
		10°C 이상	ISO VG 320	
	중하중	10°C 이하	ISO VG 320	
		10°C 이상	ISO VG 460	

Factory Charged Lubricant

Product	Load Status	Temperature	Charged Lubricant	Remarks
Planetary Gear Reducer Geared Motor	Total Load	10°C below	ISO VG 150	
		10°C up	ISO VG 220	
Worm	Normal Load	10°C below	ISO VG 220	
		10°C up	ISO VG 320	
	Heavy Load	10°C below	ISO VG 320	
		10°C up	ISO VG 460	

- 매우 격심한 부하조건외의 표준형 감속기에는 한단계 높은 점도의 윤활유를 사용하는 것이 좋습니다.
- 그리스이 전용 기어모터에는 NLGI 0 을 사용하십시오.
- 주위온도가 40°C 이상되는 경우에는 당사에 문의하여 주십시오.
- 사용온도가 높은 경우에는 한단계 높은 점도유를 선택하십시오.

- For severe load, It is recommended to use one-step up grease for standard geared motor.
- Greased motor needs to use NLGI 0.
- For use of motor at higher than 40°C, Please ask us for direction.
- When normal running temperature is high, choose a one-step up viscosity grease.

삼상 I.E.C 플랜지 모터

3-Phase I.E.C Flange Motor

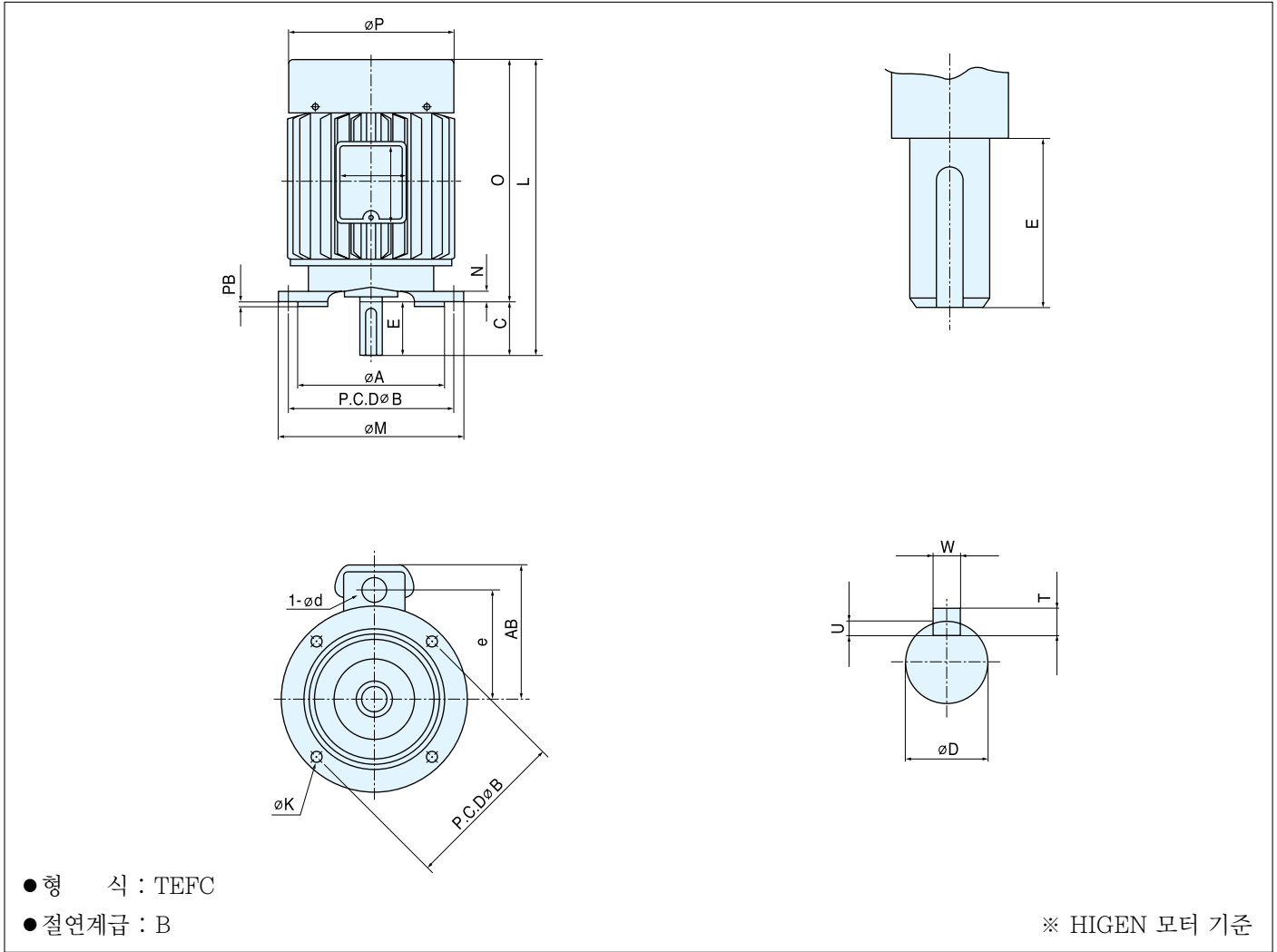

- Type : TEFC
- Insulation class : B

Frame 프레임	출력(KW)		치 수 표 (Dimension)											축(Shaft)				
			전 동 기 (Motor)															
	4극	6극	L	ϕA	ϕB	C	E	AB	N	ϕM	O	ϕP	PB	ϕK	U	W	ϕD	T
63	0.2	-	262	110j6	130	23	23	-	10	160	239	132	3.5	10	1	-	11j6	-
71	0.4	-	270	110j6	130	30	30	115	10	160	240	132	3.5	10	3	5	14j6	5
80	0.4	0.4	293	130j6	165	40	40	140	12	200	253	175	3.5	12	3.5	6	19j6	6
90	1.5	0.75	356	130j6	165	50	50	161	12	200	306	192	3.5	12	4	8	24j6	7
100	2.2	1.5	368	180j6	215	60	60	168	16	250	308	196.5	4	15	4	8	28j6	7
112	3.7	2.2	412	180j6	215	60	60	182	16	250	352	235	4	15	4	8	28j6	7
132	5.5	3.7	458	230j6	265	80	80	213	20	300	378	274	4	15	5	10	38k6	8
132	7.5	5.5	498	230j6	265	80	80	213	20	300	418	274	4	15	5	10	38k6	8

GEAR HEAD(I.E.C FLANGE TYPE)

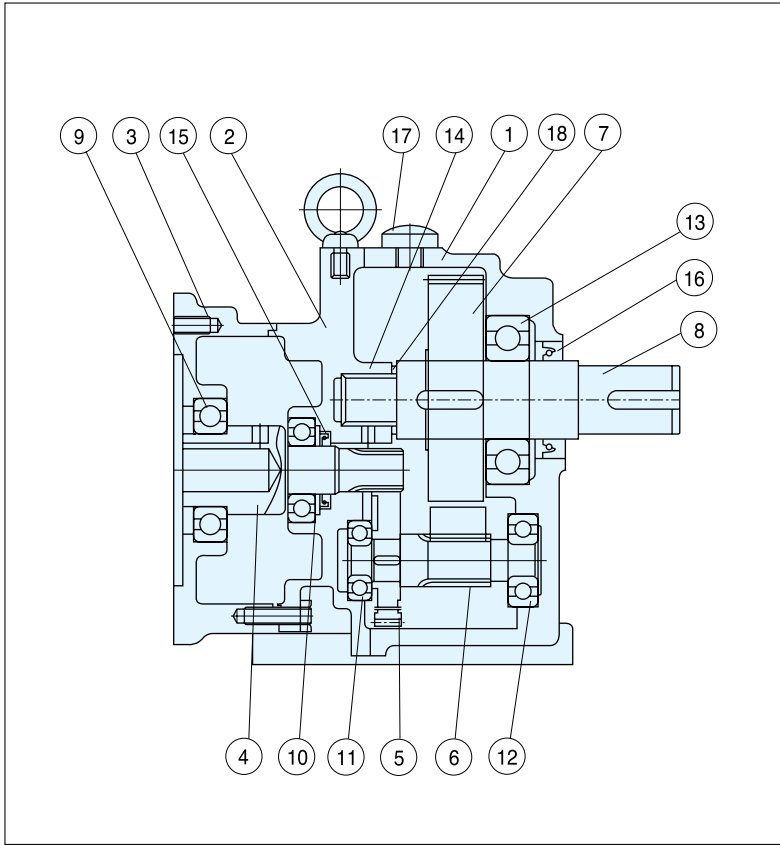

GMSM153H30

- | | |
|-----------|---------------|
| 1. 케이스 | Case |
| 2. 모터 플랜지 | Motor Flange |
| 3. 모터 브라켓 | Motor Bracket |
| 4. 피니온 #1 | 1st Pinion |
| 5. 기어 #1 | 1st Gear |
| 6. 피니온 #2 | 2nd Pinion |
| 7. 기어 #2 | 2nd Gear |
| 8. 출력축 | Output Shaft |
| 9. 베어링 | Bearing |
| 10. 베어링 | Bearing |
| 11. 베어링 | Bearing |
| 12. 베어링 | Bearing |
| 13. 베어링 | Bearing |
| 14. 부쉬 | Dx - Bush |
| 15. 오일 씬 | Oil Seal |
| 16. 오일 씬 | Oil Seal |
| 17. 공기통 | Air Vent |
| 18. 스페이서 | Spacer |

규격 (Specification)

Motor (60Hz) kW		FRAME NO.	RATIO	MOTOR SIDE												C	E	F	G	H	I	J	L	M	N	P	Q	QK	S	T	U	W	Z	APPR. Weight (kg)
4P	6P			LA	LB	LC	LE	Sh	Wh	Th	A	Y	R																					
0.4	-	F105	1/5																															
			1/10																															
			1/20																															
			1/30	130	110	160	4	14	5	16.3	34	8	15	105	67.5	90	12	160	-	35	196	175	120	60	40	35	28	7	4	7	12	7		
			1/40																															
			1/50																															
0.75	0.4	F135	1/5																															
			1/10																															
			1/20																															
		1/30	165	130	200	4	19	6	21.8	42	10	Thru (15)	135	90	135	18	218	259.5	45	236.3	210	165	72	55	45	32	8	5	10	15	25			
		1/40																																
		1/50																																
F153	1/60																																	
	1/50																																	

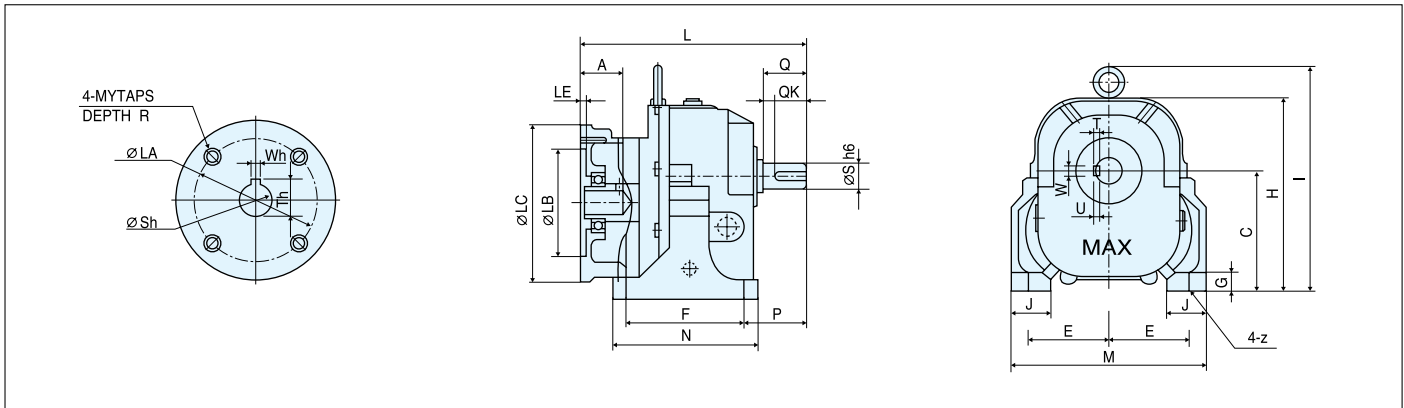

MOTOR (60Hz) kW		FRAME No.	RATIO	Motor Side										C	E	F	G	H	I	J	L	M	N	P	Q	QK	S	T	U	W	Z	APPR. WEIGHT (kg)
4P	6P			LA	LB	LC	LE	Sh	Wh	Th	A	Y	R																			
1.5	0.75	F153	1/5																													
			1/10																													
			1/20																													
		1/30	165	130	200	4	24	8	27.3	54	10	20	153	107.5	150	22	246	287.5	50	286.8	250	185	78	55	45	38	8	5	10	15	35	
		1/40																														
		1/50																														
2.2	1.5	F172	1/5																													
			1/10																													
			1/20																													
		1/30																														
		1/40																														
		1/50																														
3.7	2.2	F172	1/5																													
			1/10																													
			1/20																													
		1/30	215	180	250	4	28	8	31.3	65	12	20	172	116	172	25	282	323.5	60	339.8	276	216	113.5	82	75	45	9	5.5	14	19	50	
		1/40																														
		1/50																														
5.5	3.7	F181	1/5																													
			1/10																													
			1/20																													
		1/30	205	135	290	30	340	391	75	390.8	350	340	114	82	75	55	10	6	16	24	95											
		1/40																														
		1/50																														
7.5	5.5	F205	1/5																													
			1/10																													
			1/20																													
		1/30	235	150	320	35	379	439	80	459.8	390	370	135	105	63	65	11	7	18	24	120											
		1/40																														
		1/50																														
7.5	5.5	F235	1/5																													
			1/10																													
			1/20																													
		1/30	265	230	300	4	38	10	41.3	81	14	25	270	180	350	40	436	496	80	471.9	440	410	140	105	80	70	12	7.5	20	28	140	
		1/40																														
		1/50																														
7.5	5.5	F270	1/5																													
			1/10																													
			1/20																													
		1/30	181	120	245	25	293	344	70	391.8	310	295	111	82	75	50	9	5.5	14	19	70											
		1/40																														
		1/50																														

GEARED MOTOR

0.2kW (1/4 HP, 3-Phase 삼상)

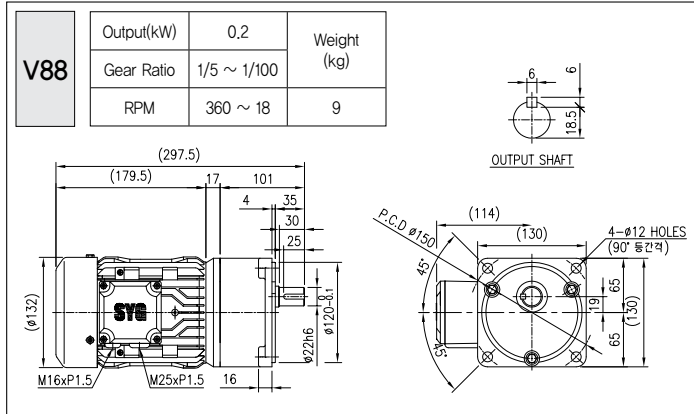
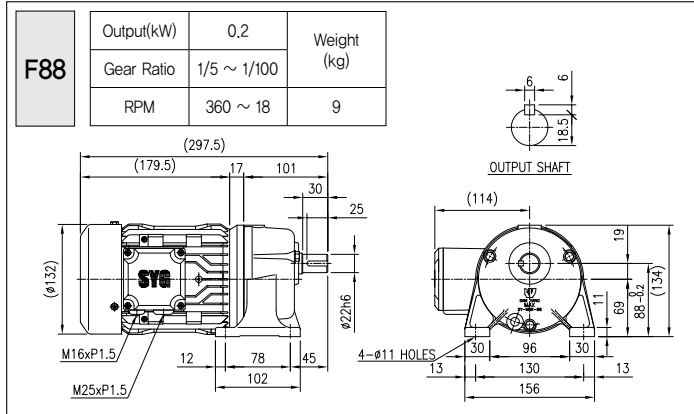

0.4kW (1/2 HP, 3-Phase 삼상)

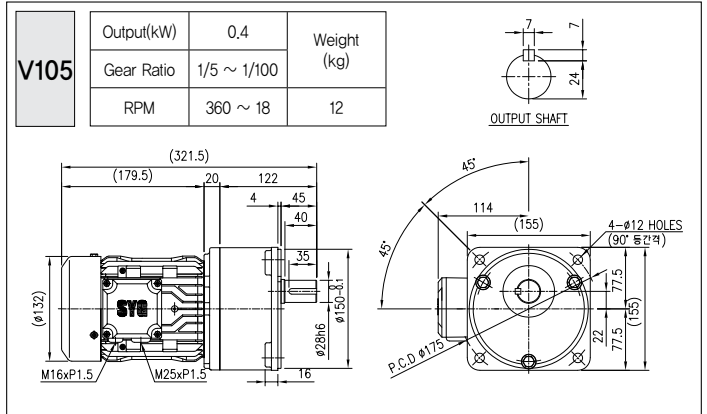
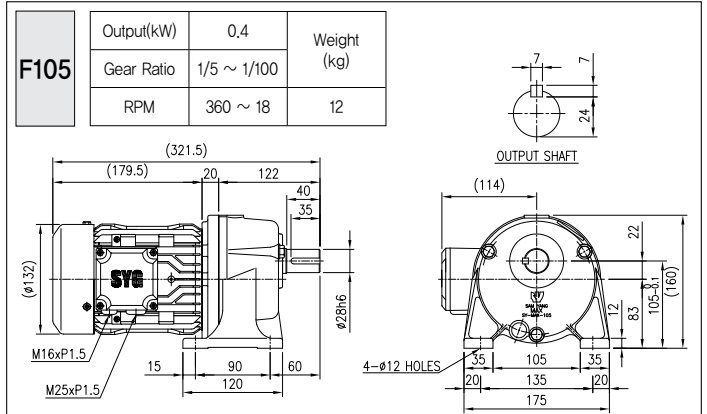

0.2kW (1/4 HP, 1-Phase 단상)

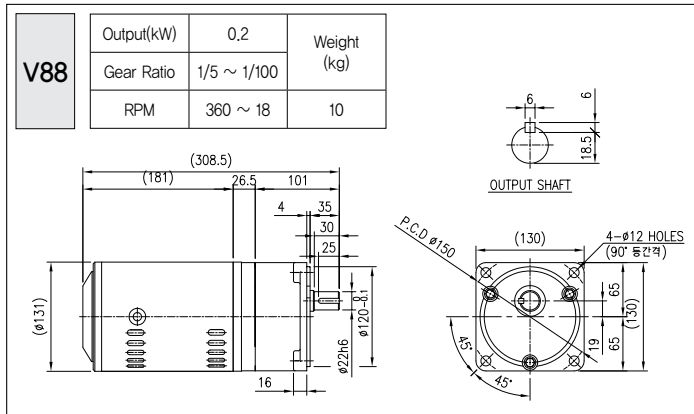
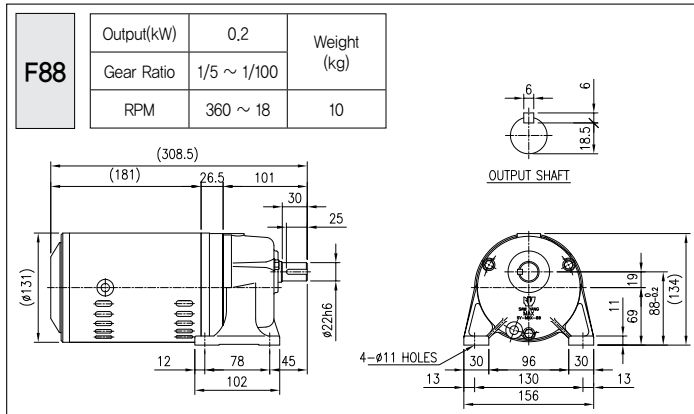

0.4kW (1/2 HP, 1-Phase 단상)

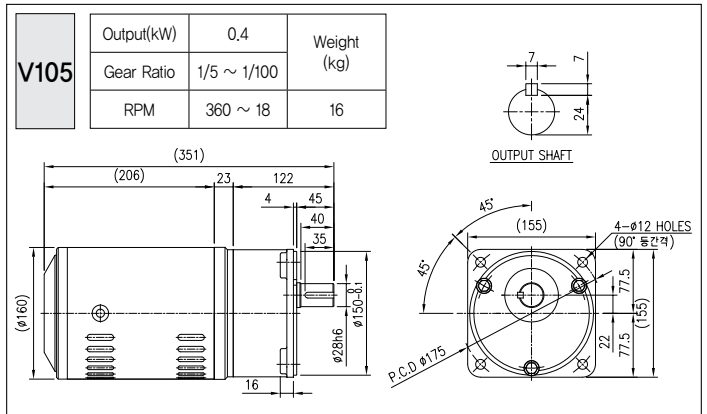
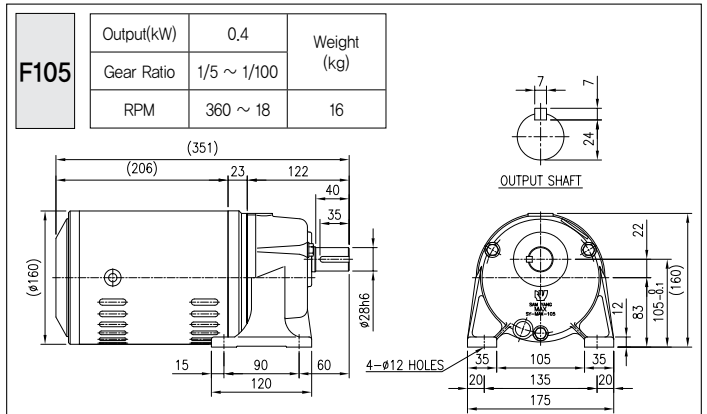

LINE POWER

0.2kW(1/4 HP) Line Power

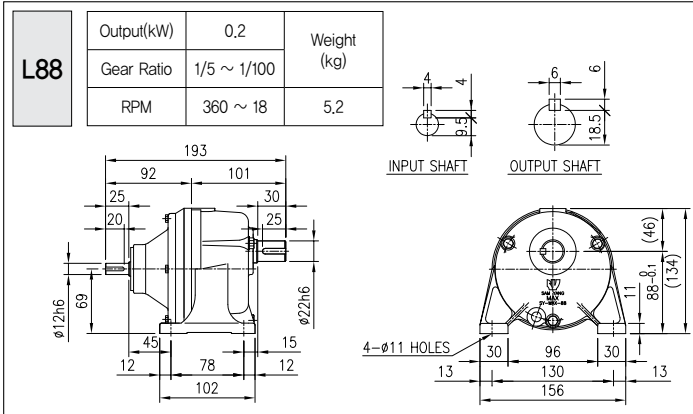

0.4kW(1/2 HP) Line Power

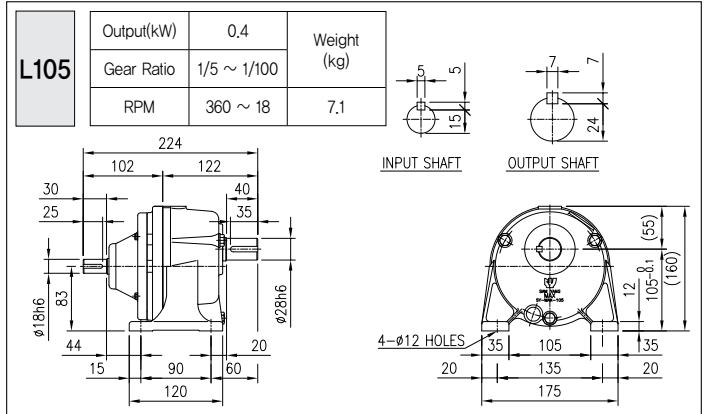

M-TYPE GEARED MOTOR

0.4kW(1/2 HP, 3-Phase 삼상)

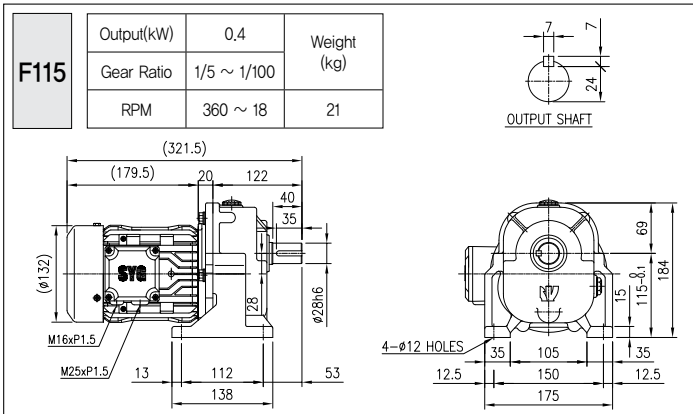

M-TYPE LINE POWER

0.4kW(1/2 HP)

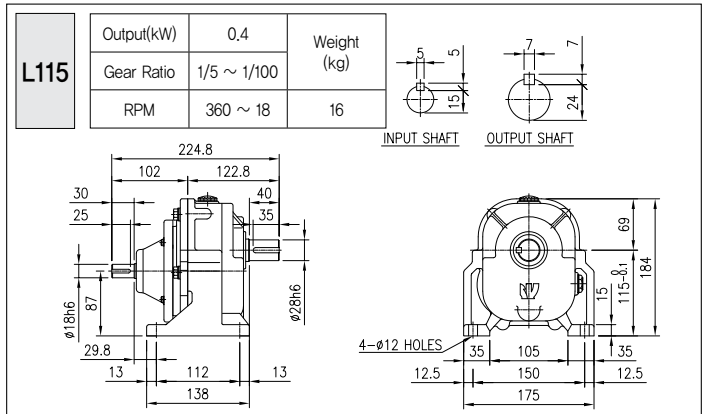

GEARED MOTOR

0.75kW(1 HP, 3-Phase 삼상)

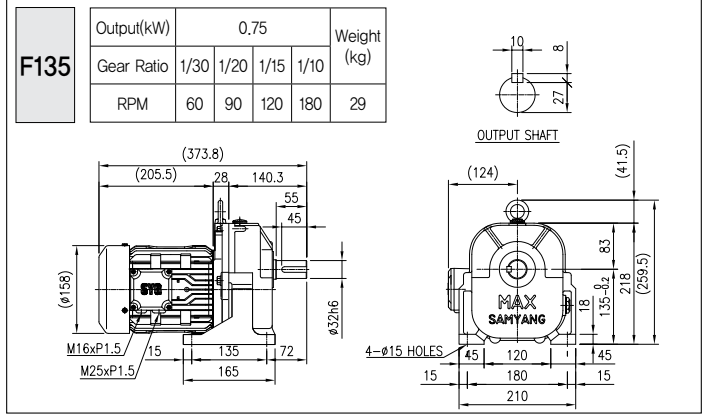
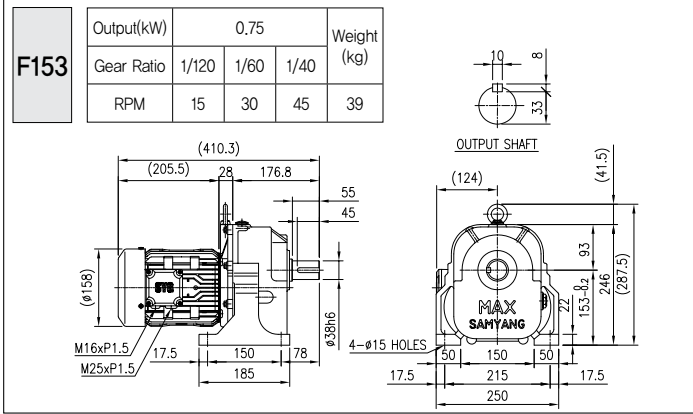

0.75kW(1 HP, 1-Phase 단상)

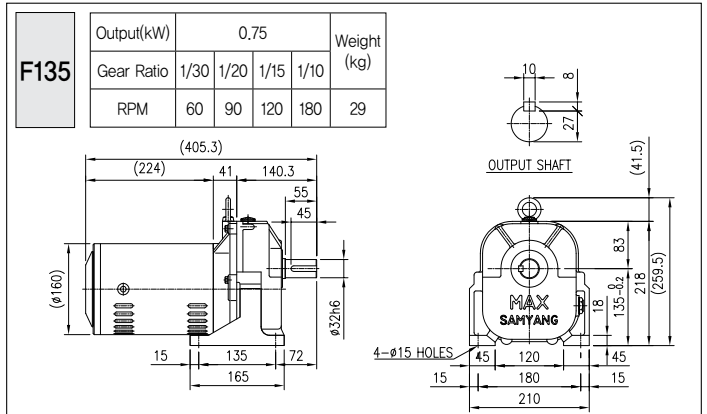
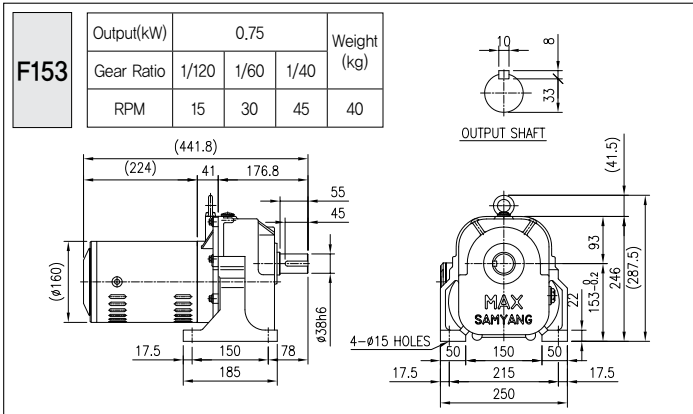

V.T GEARED MOTOR

0.75kW(1 HP, 1-Phase 단상)

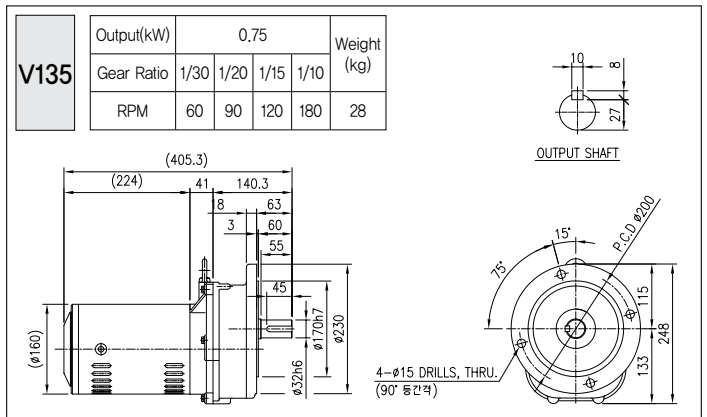
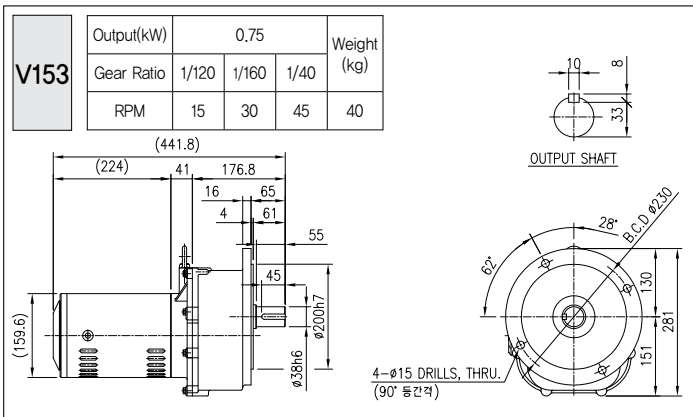

LINE POWER

0.75kW(1 HP)

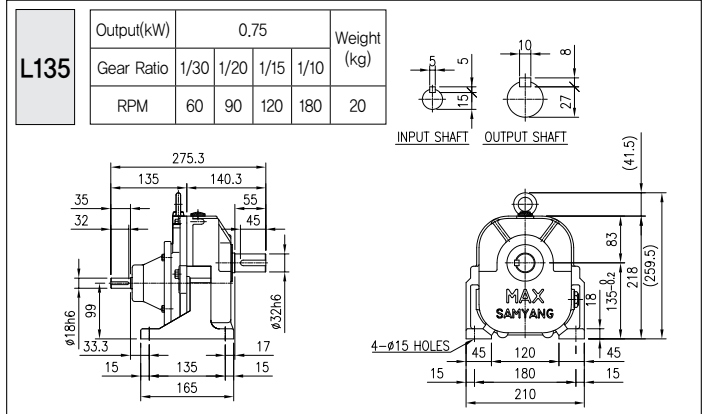
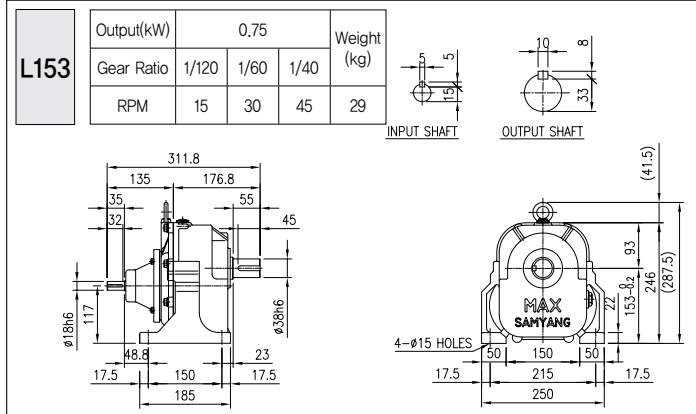

V.T GEARED MOTOR

0.75kW(1 HP, 3-Phase 삼상)

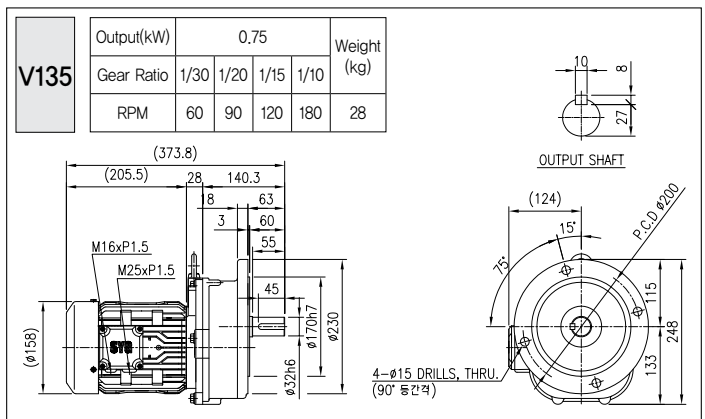
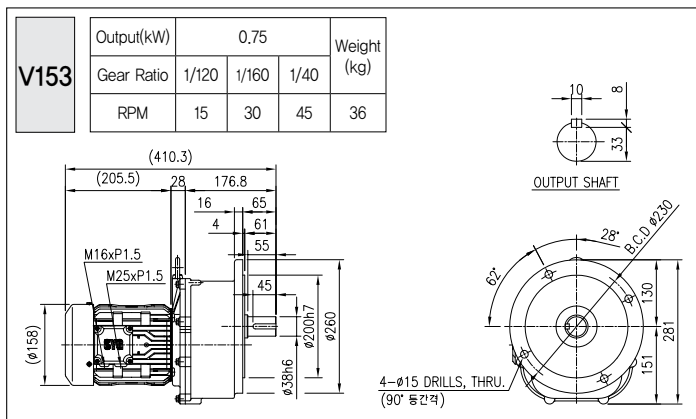

GEARED MOTOR

1.5kW(2 HP, 3-Phase 삼상)

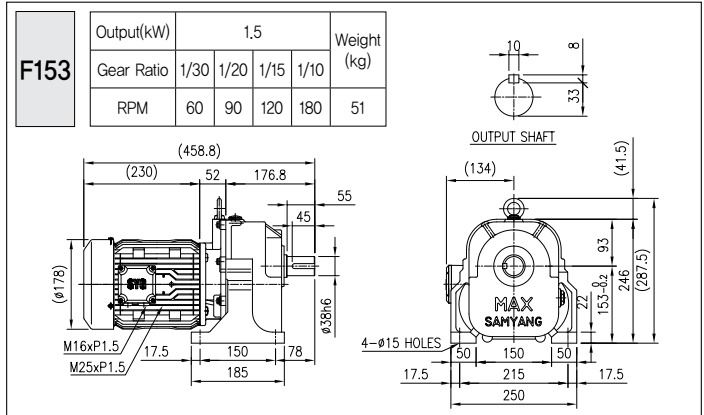
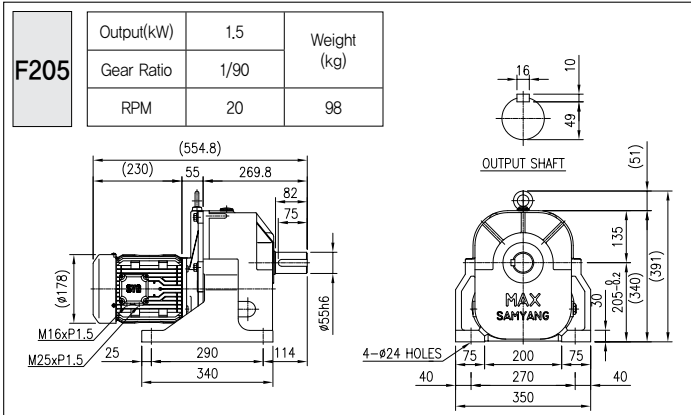
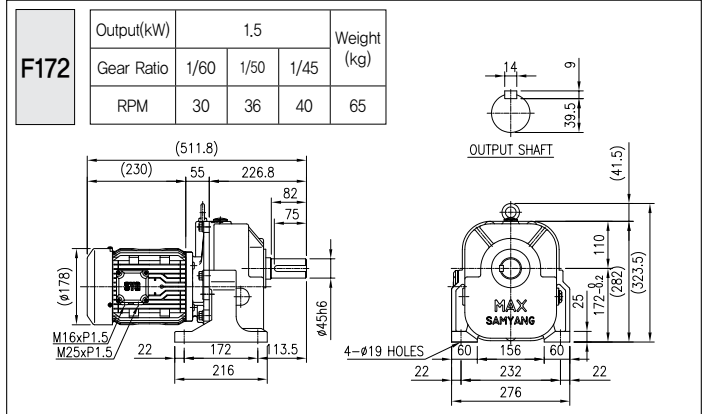
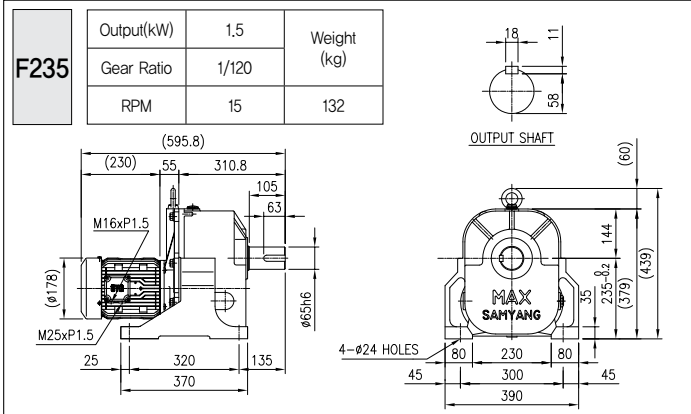

V.T GEARED MOTOR

1.5kW(2 HP, 3-Phase 삼상)

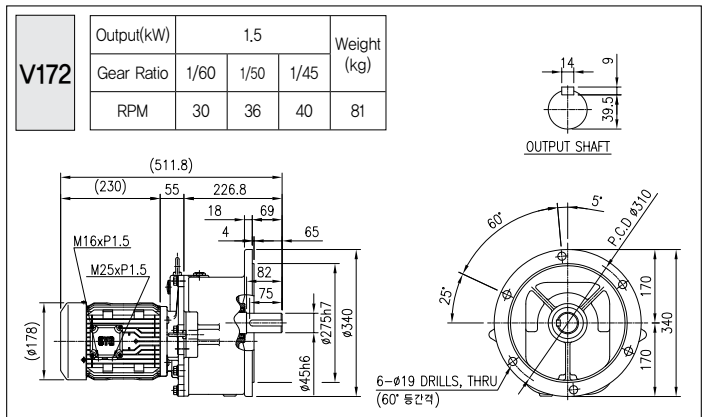
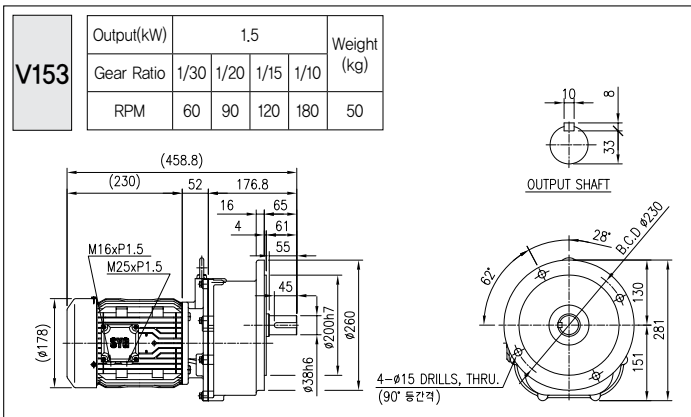

LINE POWER

1.5kW(2 HP)

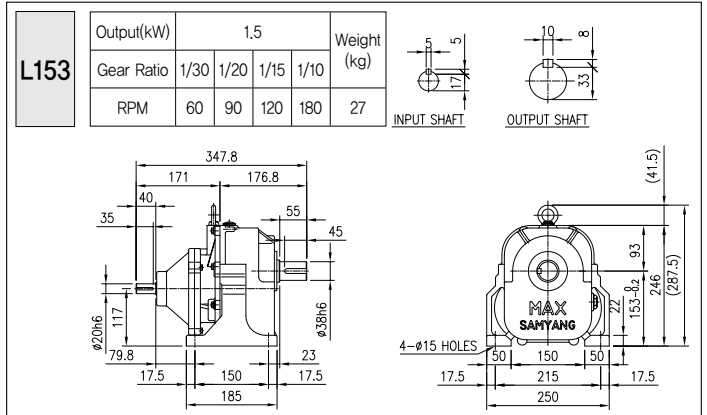
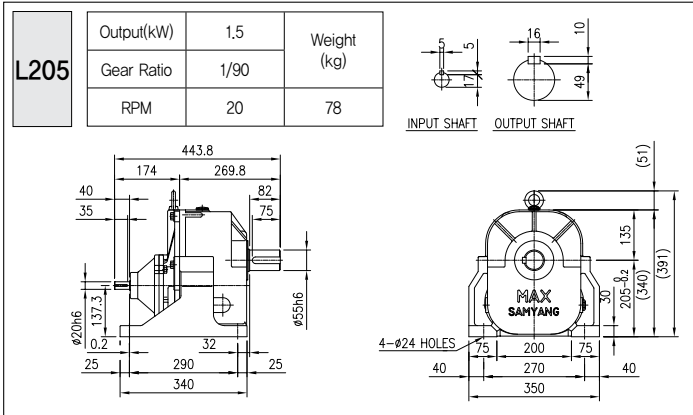
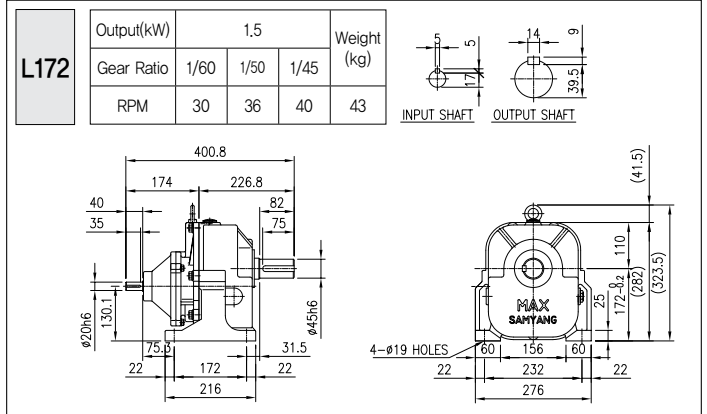
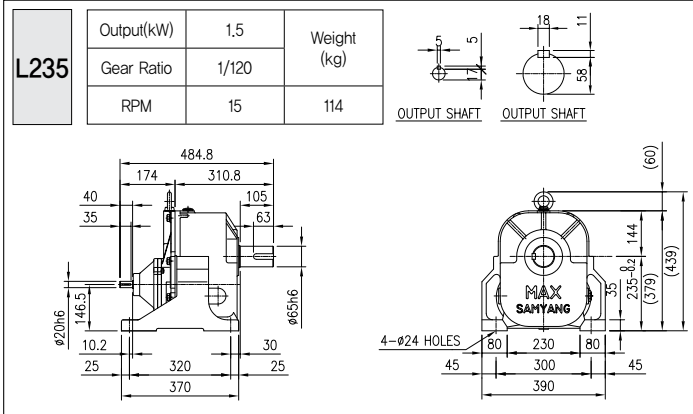

V.T GEARED MOTOR

1.5kW(2 HP, 3-Phase 삼상)

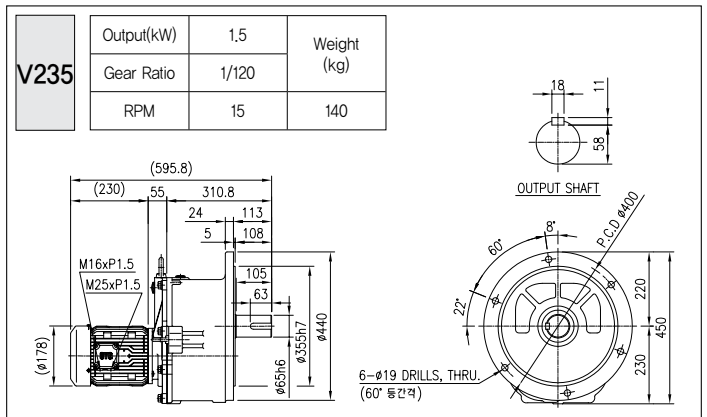
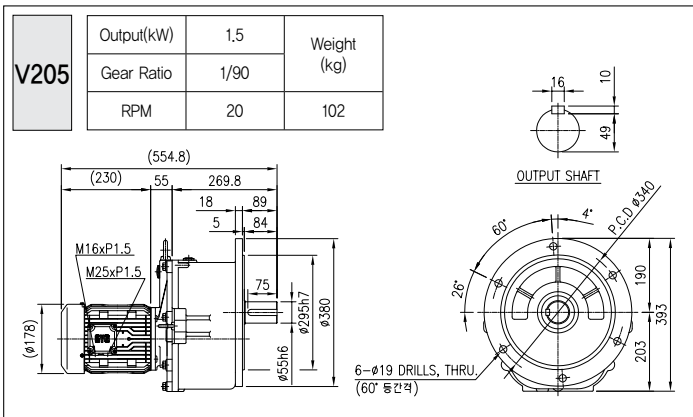

GEARED MOTOR

2.2kW(3 HP, 3-Phase 삼상)

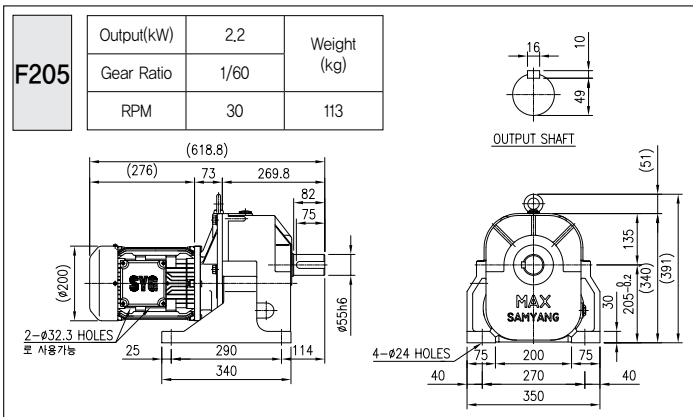
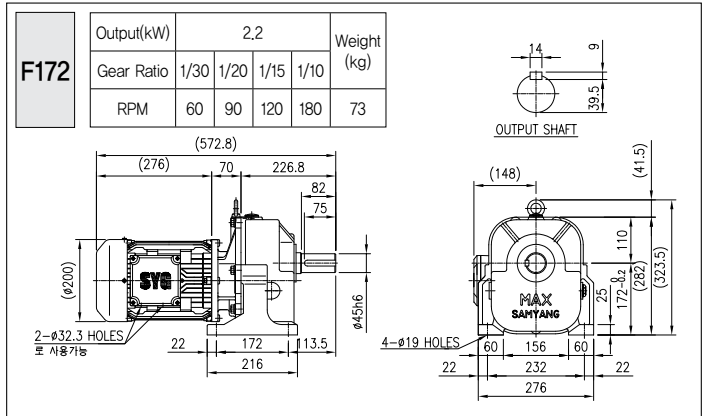
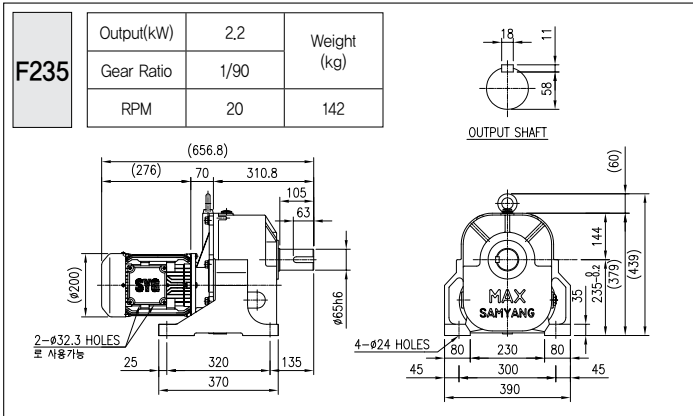
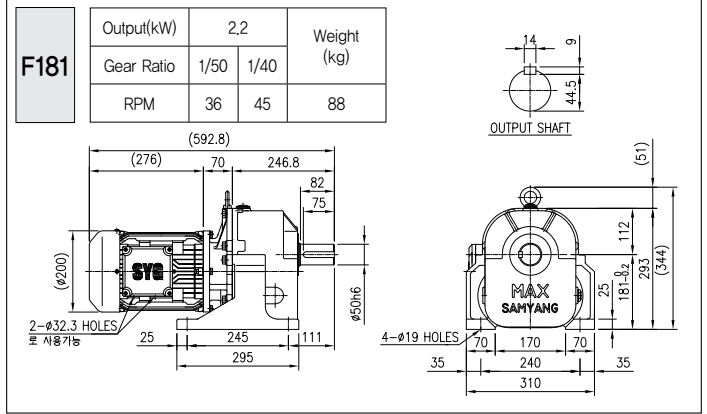
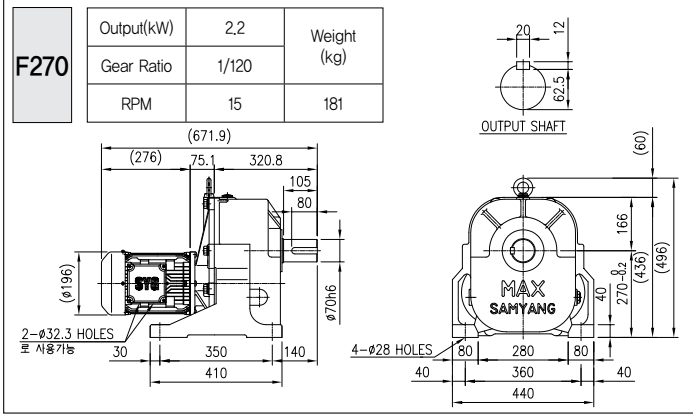

V.T GEARED MOTOR

2.2kW(3 HP, 3-Phase 삼상)

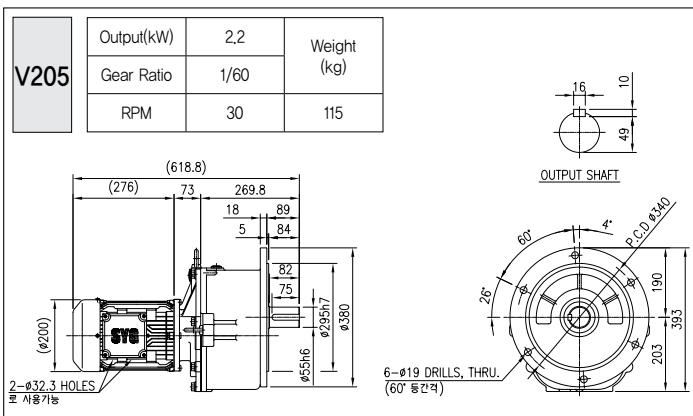
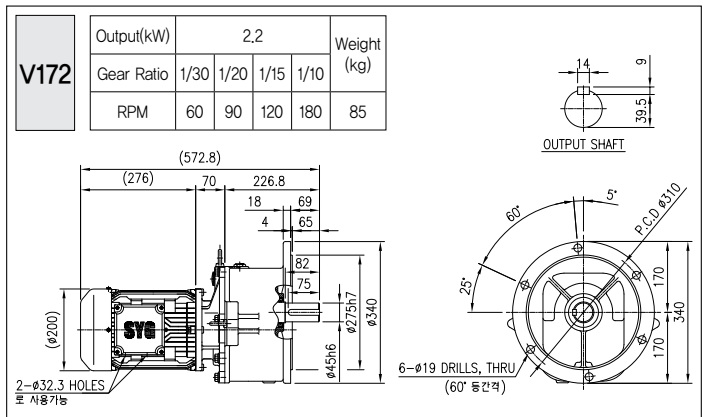
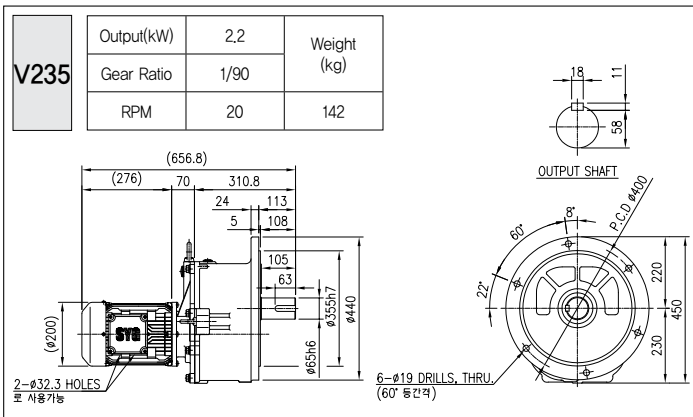
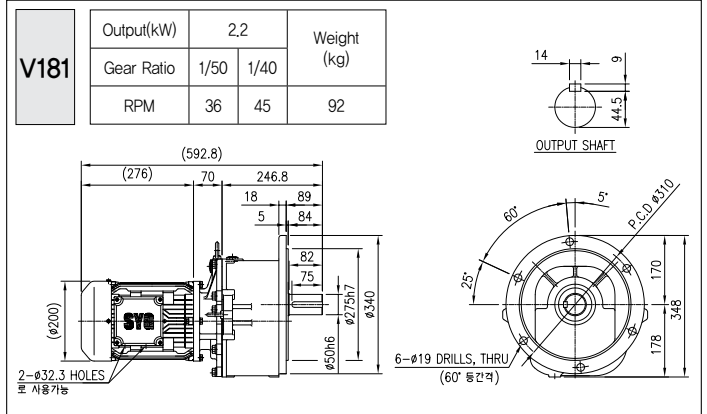
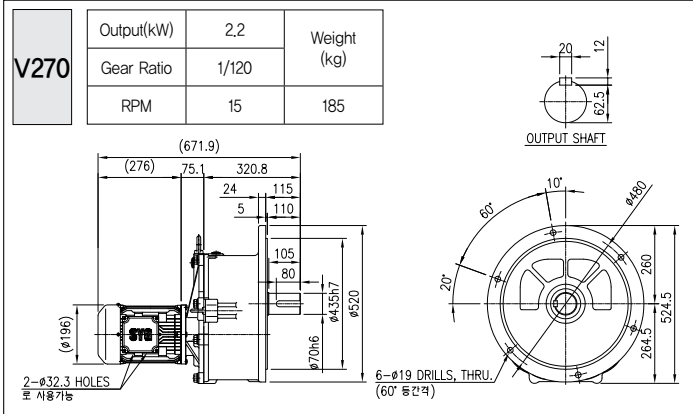

LINE POWER

2.2kW(3 HP)

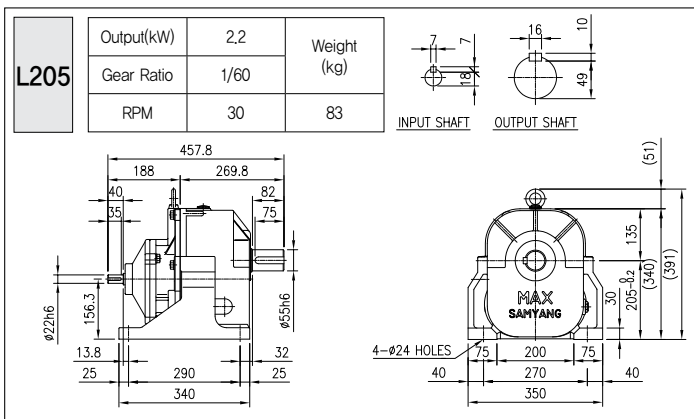
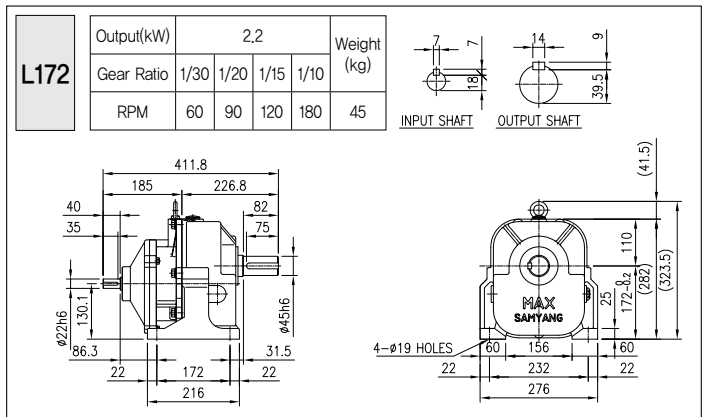
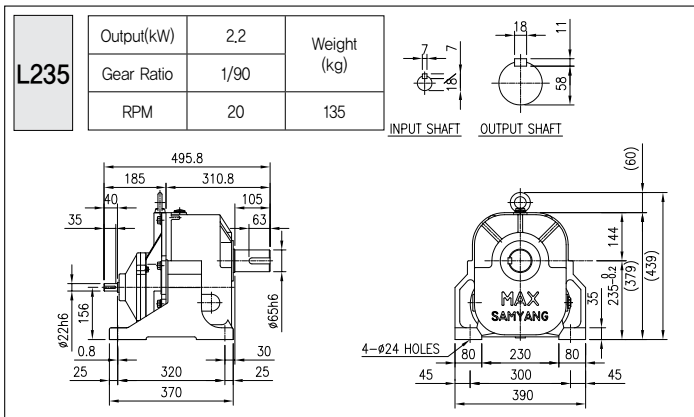
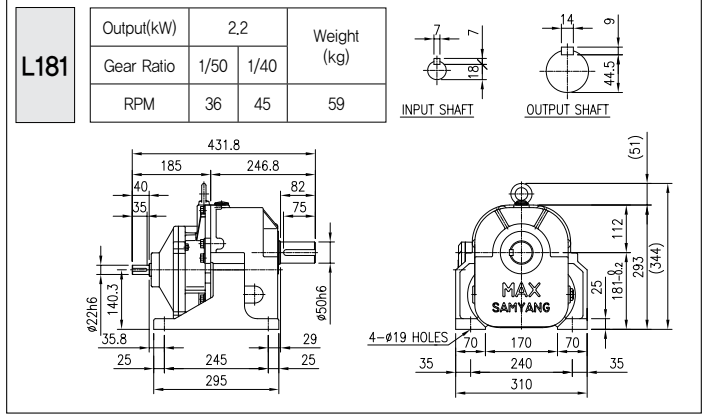
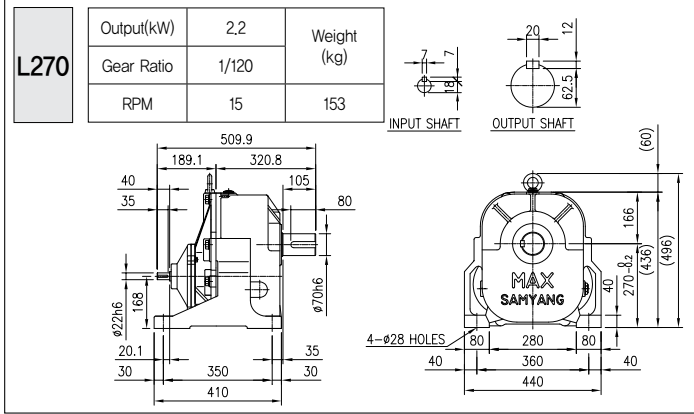

GEARED MOTOR

3.7kW(5 HP, 3-Phase 삼상)

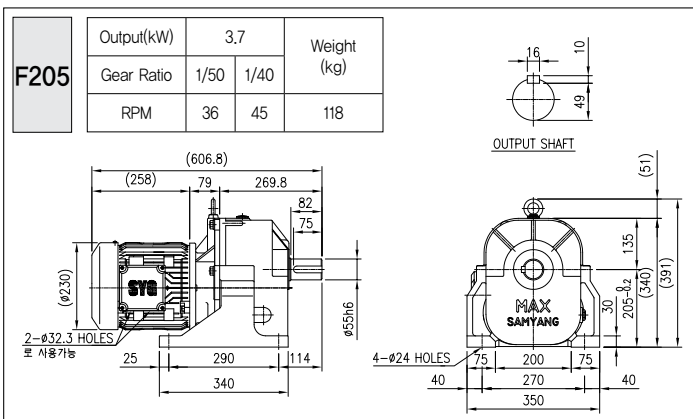
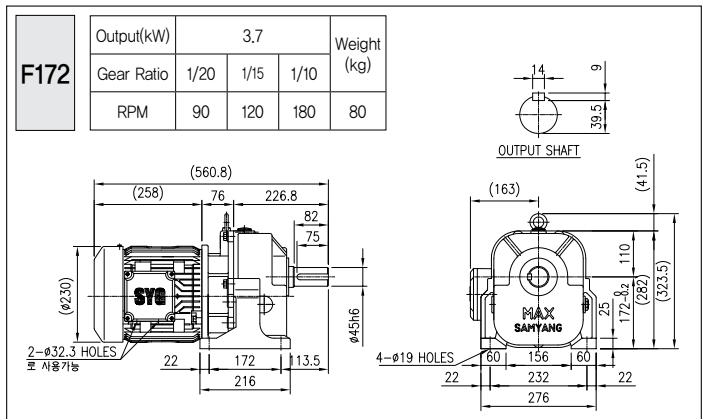
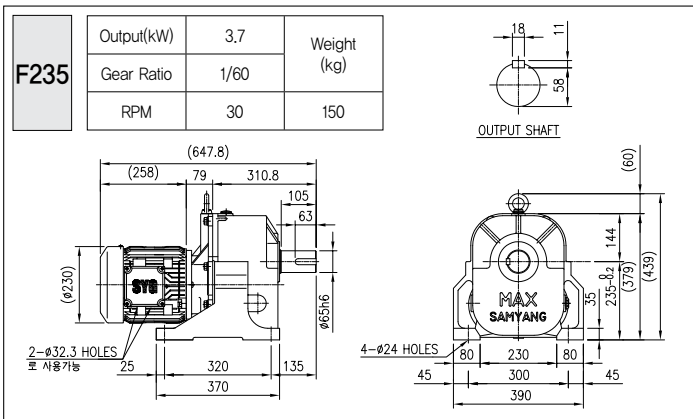
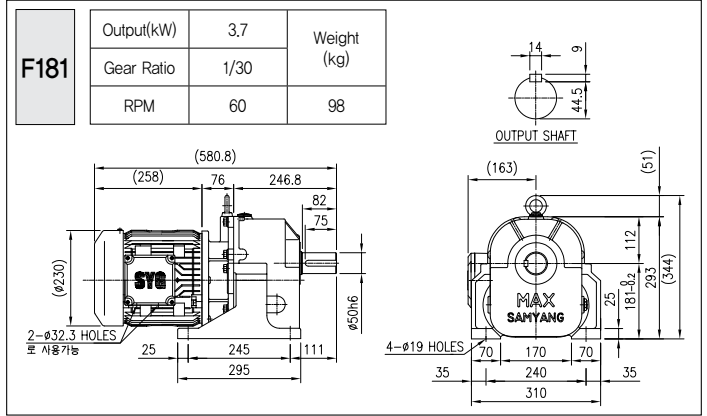
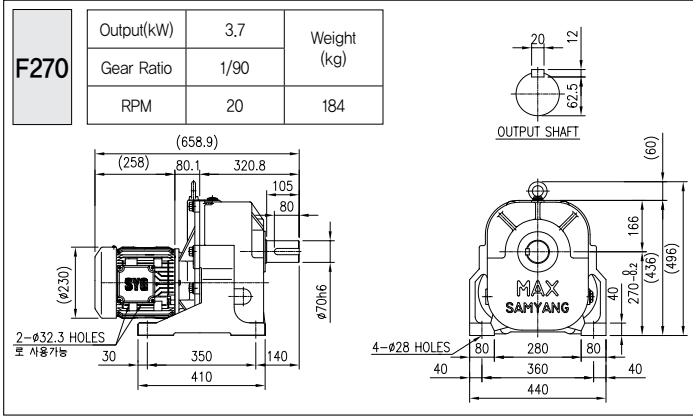

V.T GEARED MOTOR

3.7kW(5 HP, 3-Phase 삼상)

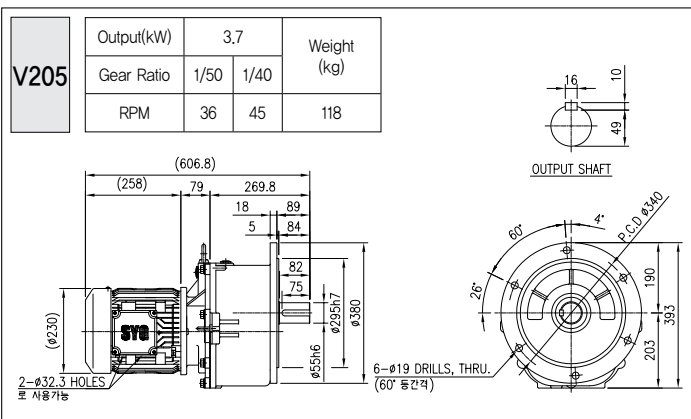
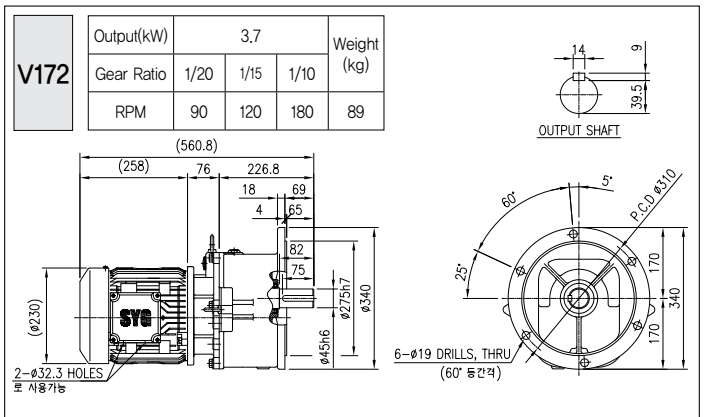
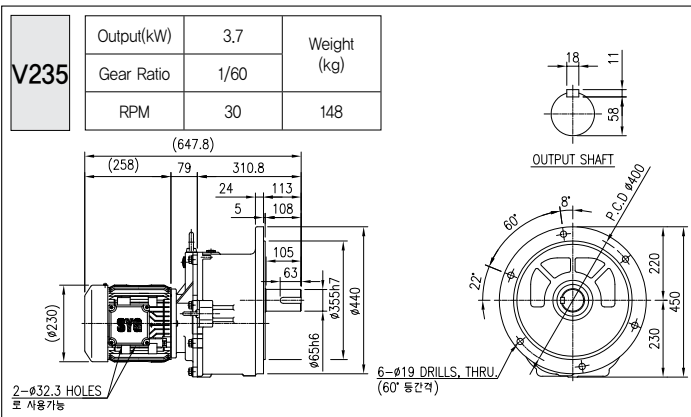
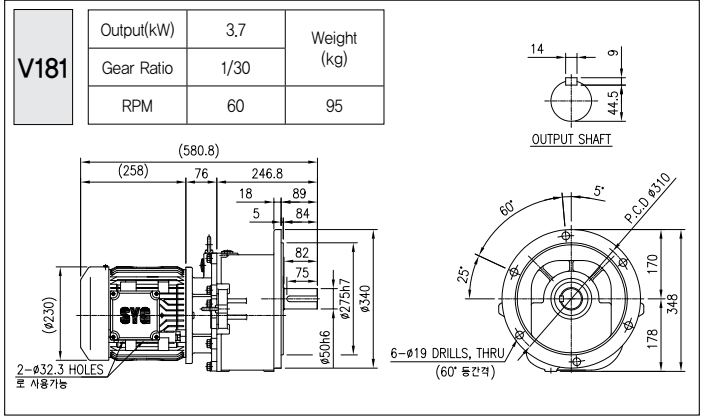
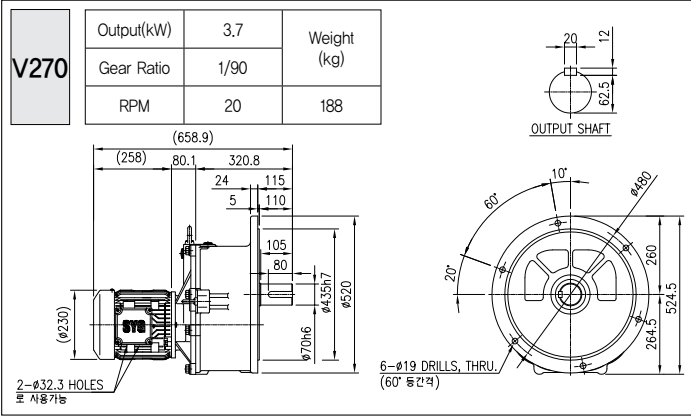

LINE POWER

3.7kW(5 HP)

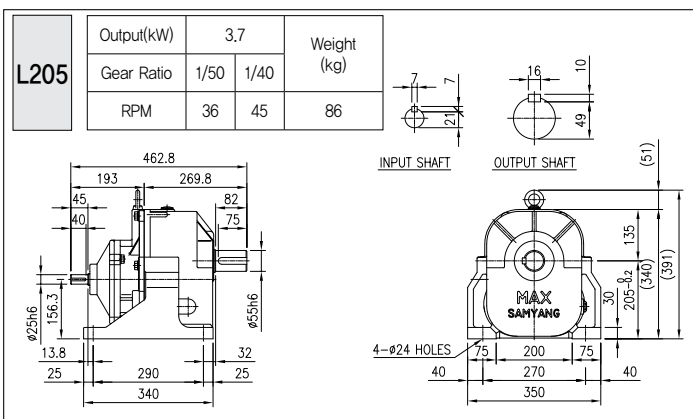
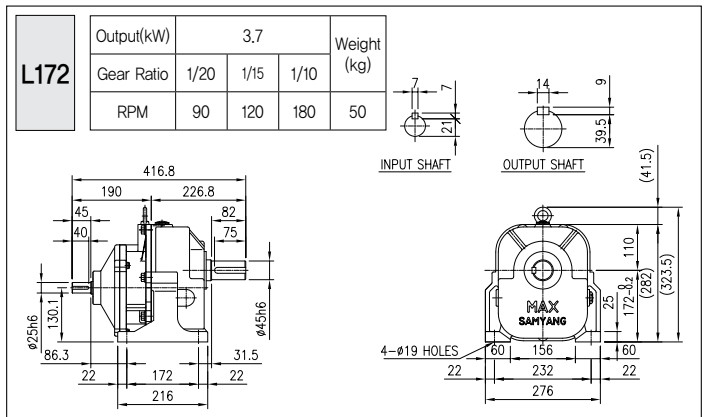
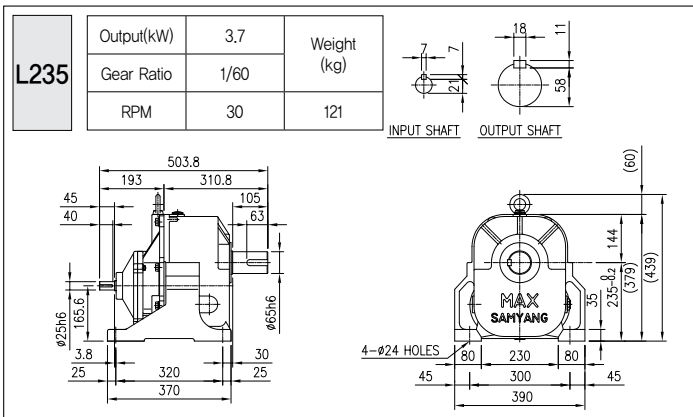
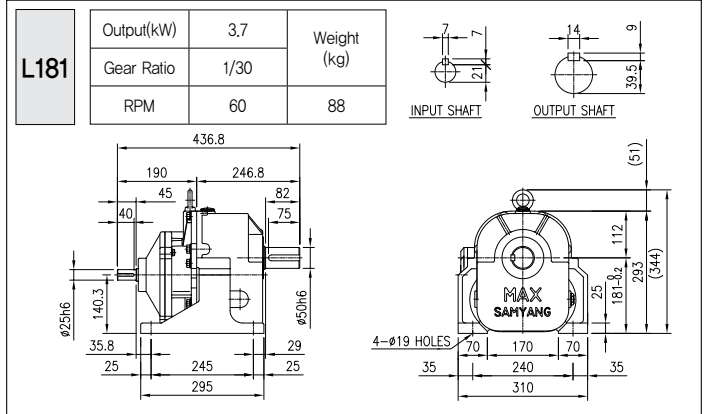
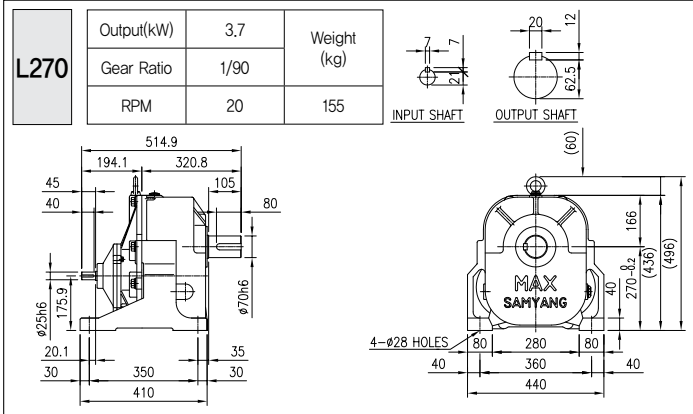

GEARED MOTOR

5.5kW(7.5 HP, 3-Phase 삼상)

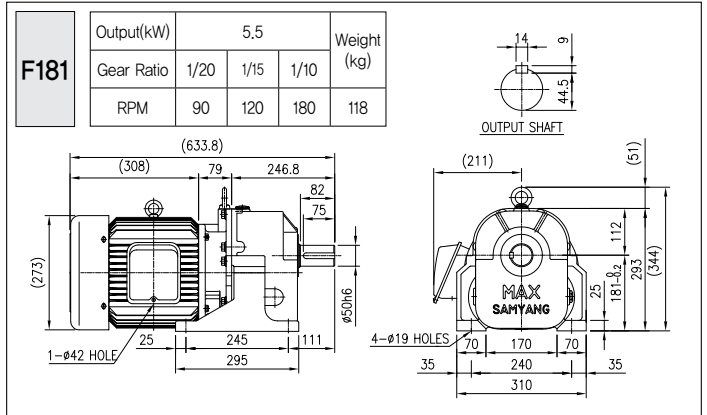
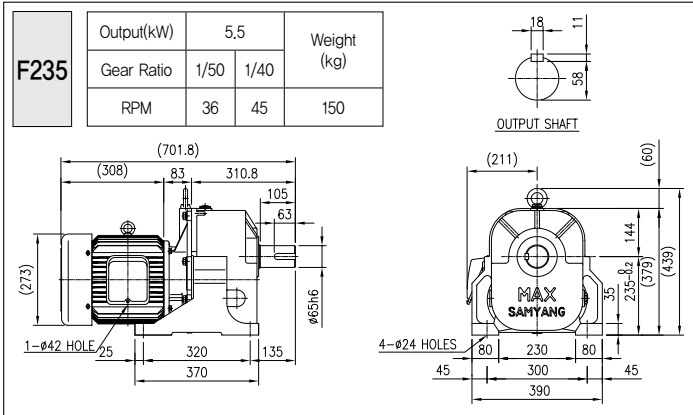
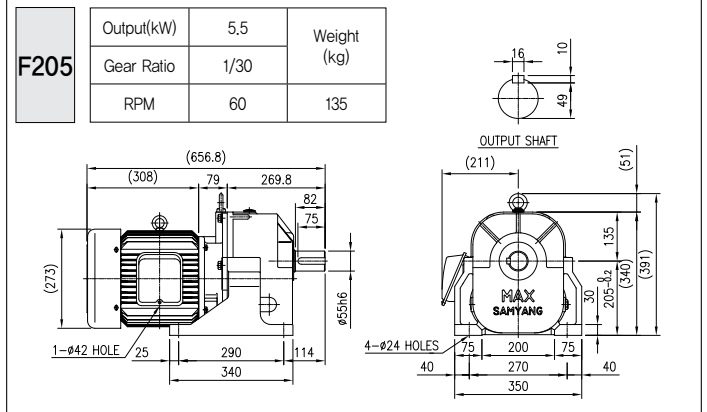
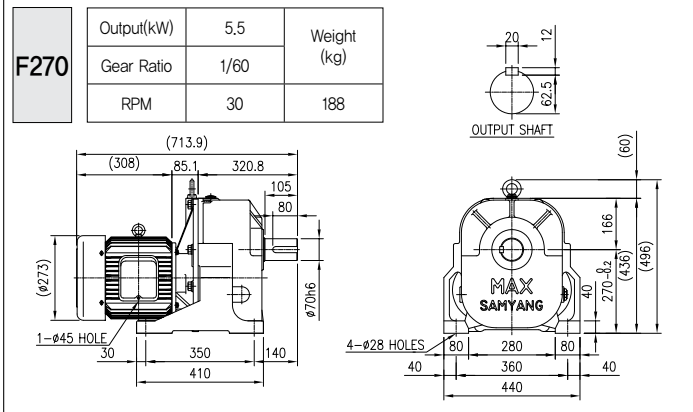

V.T GEARED MOTOR

5.5kW(7.5 HP, 3-Phase 삼상)

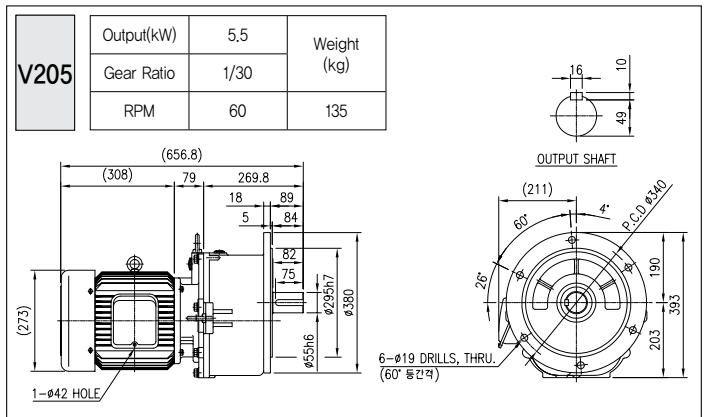
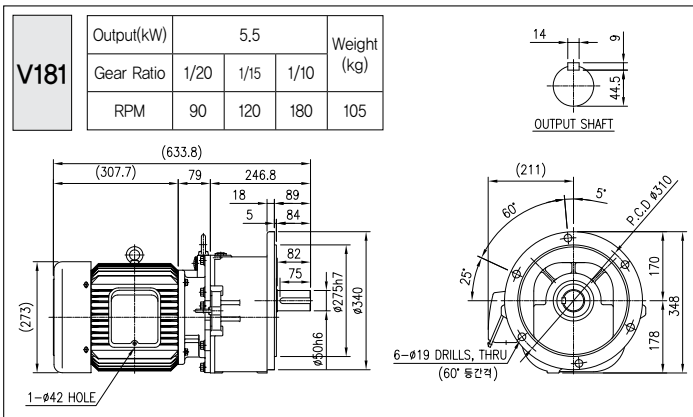

LINE POWER

5.5kW(7.5 HP)

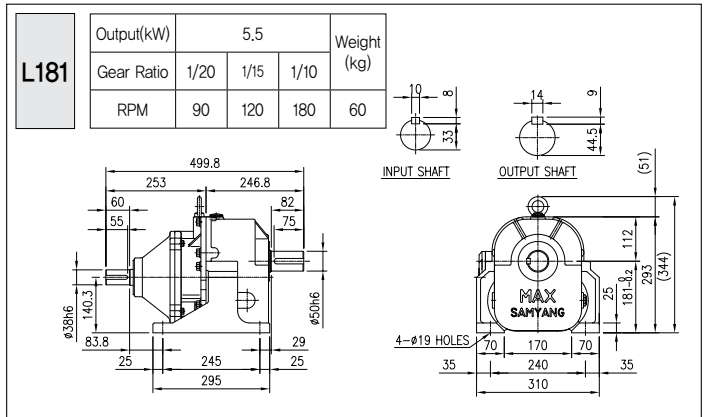
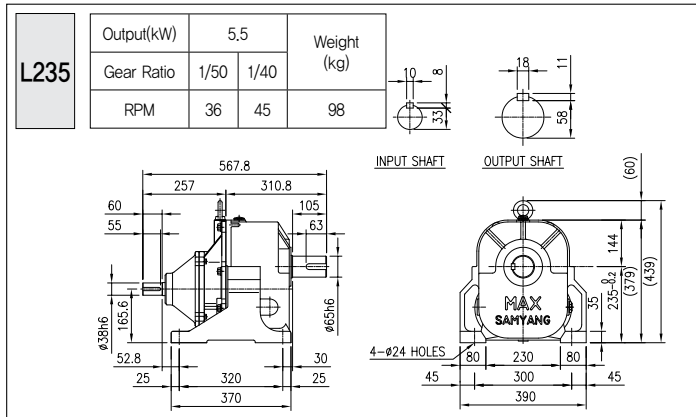
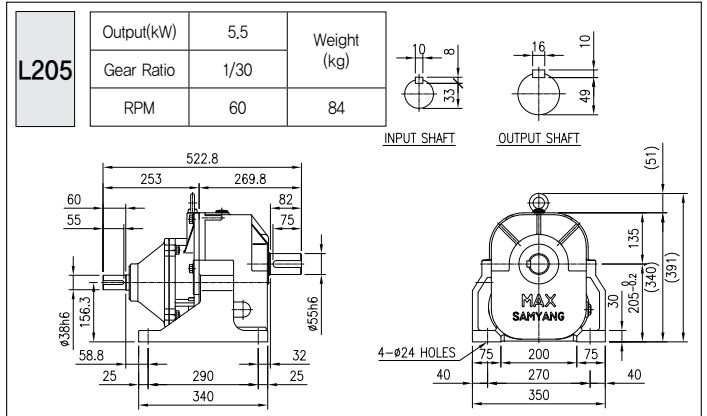
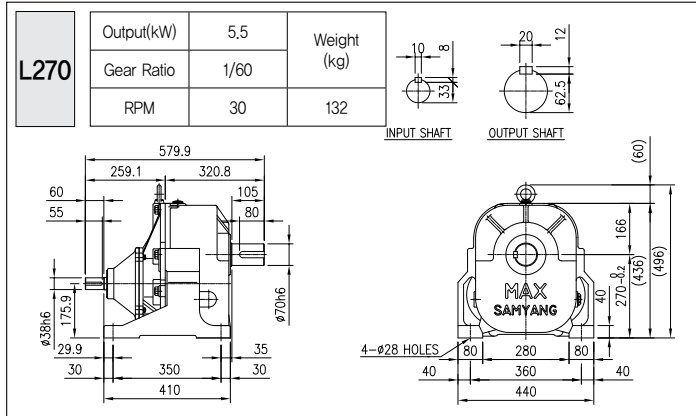

V.T GEARED MOTOR

5.5kW(7.5 HP, 3-Phase 삼상)

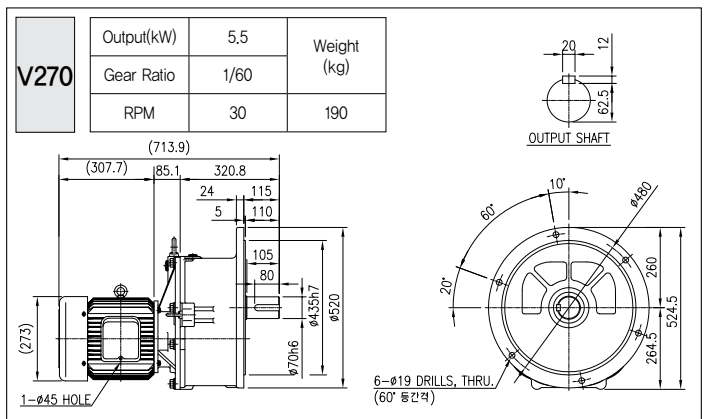
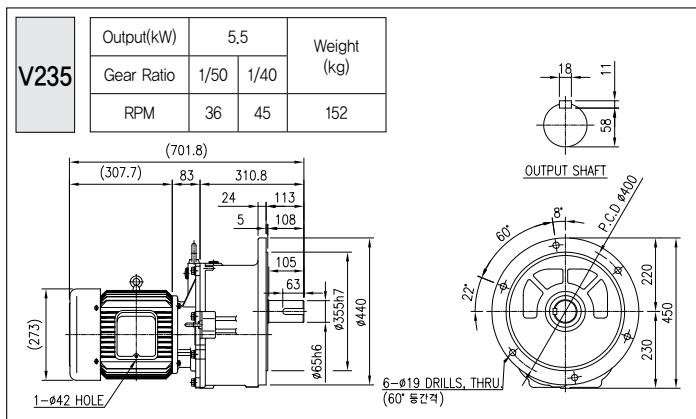

GEARED MOTOR

7.5kW(10 HP, 3-Phase 삼상)

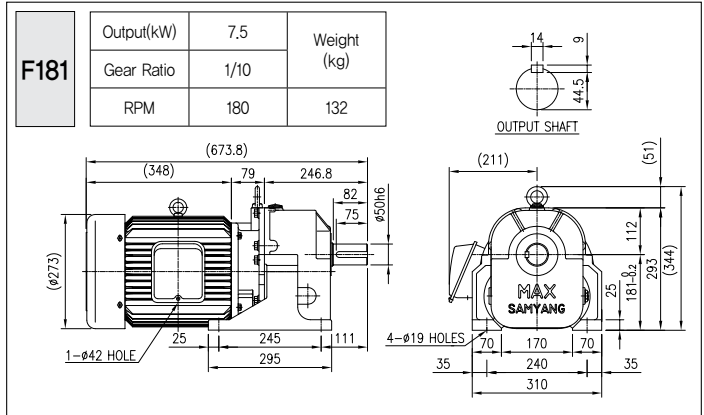
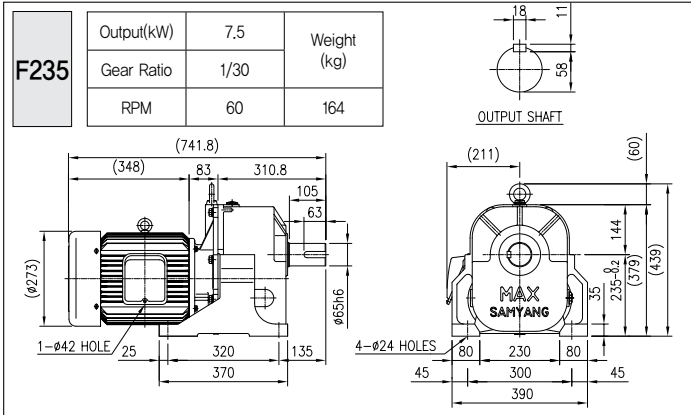
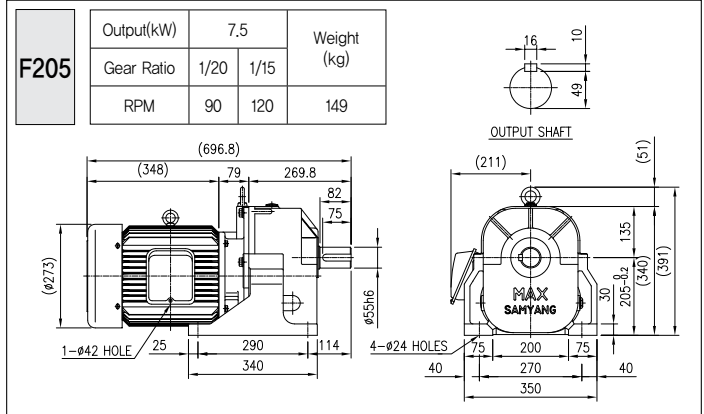
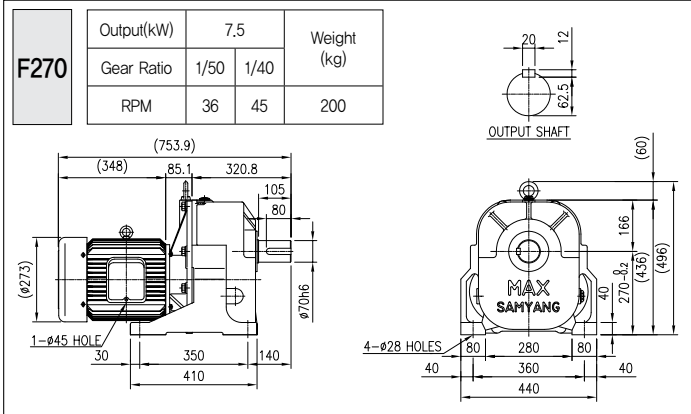

V.T GEARED MOTOR

7.5kW(10 HP, 3-Phase 삼상)

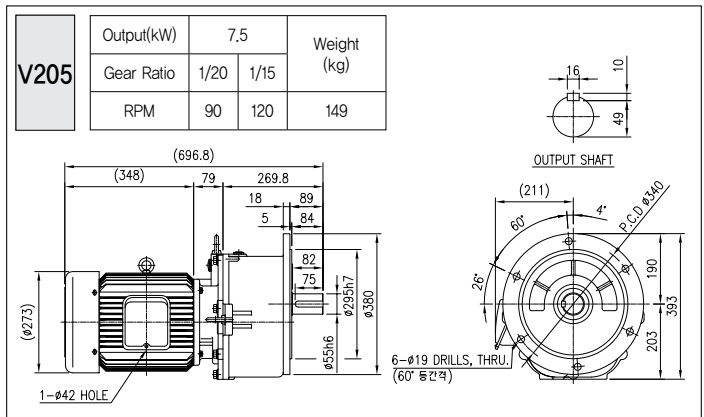
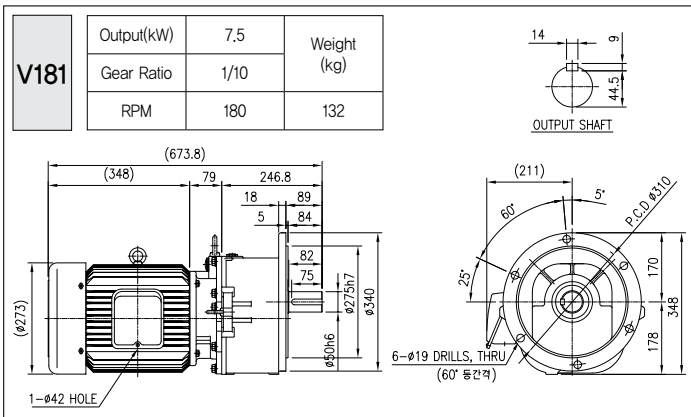

LINE POWER

7.5kW(10 HP)

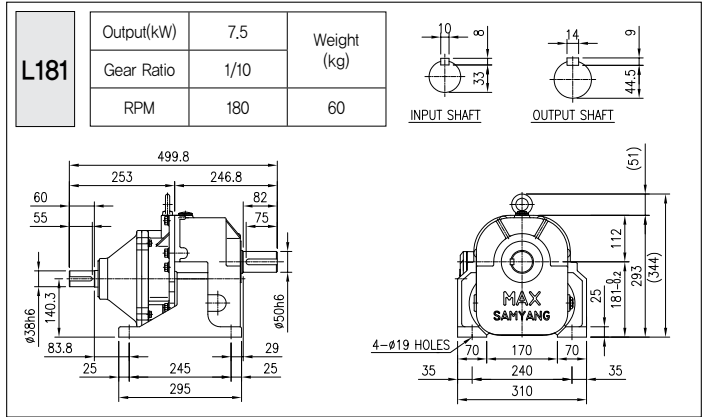
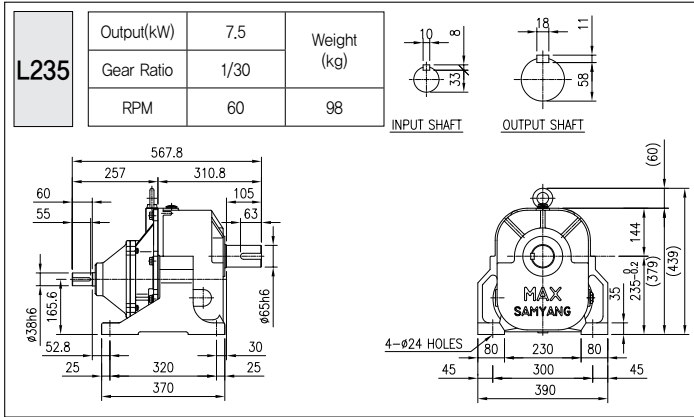
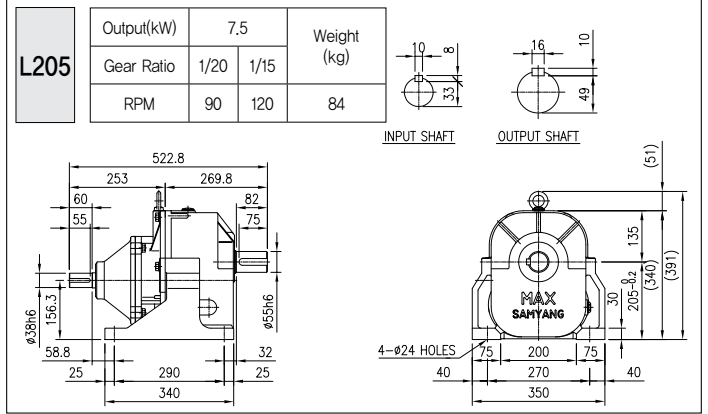
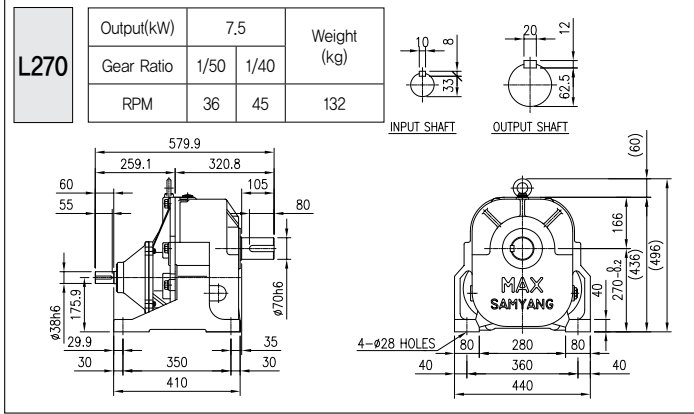

V.T GEARED MOTOR

7.5kW(10 HP, 3-Phase 삼상)

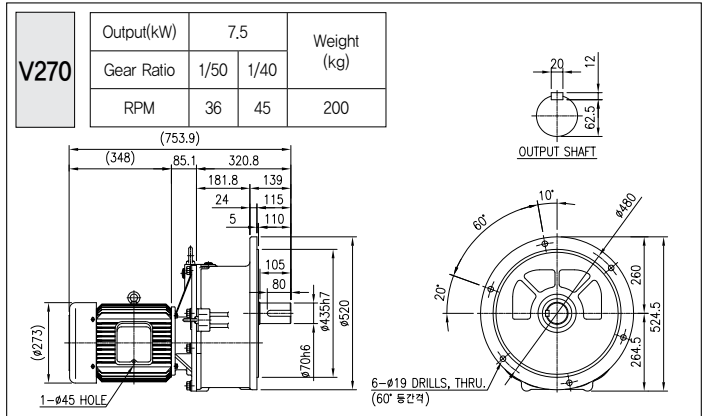
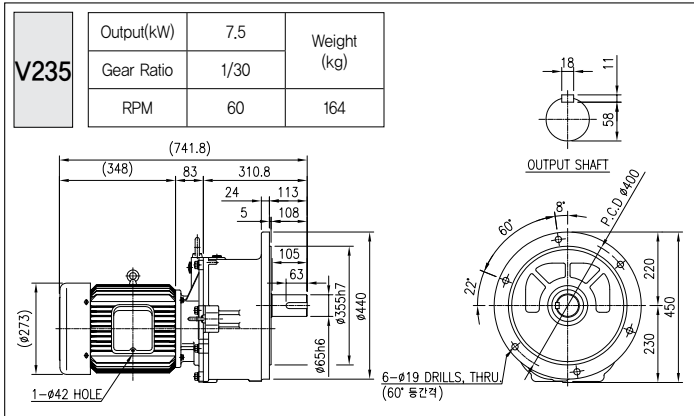

GEARED MOTOR

11kW(15 HP, 3-Phase 삼상)

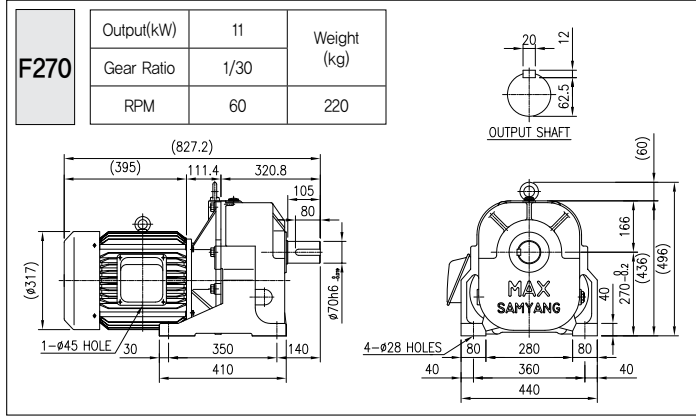

15kW(20 HP, 3-Phase 삼상)

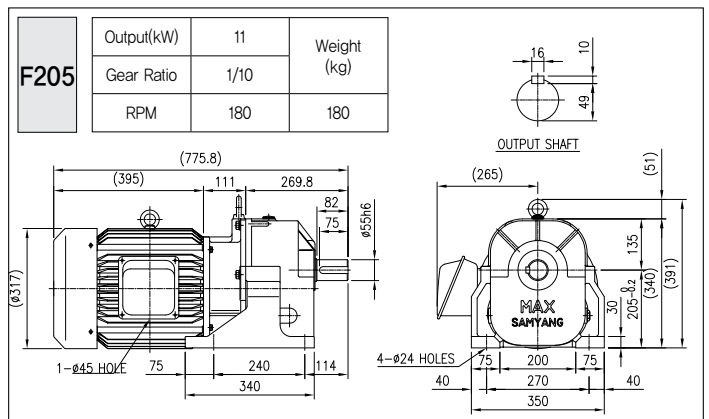
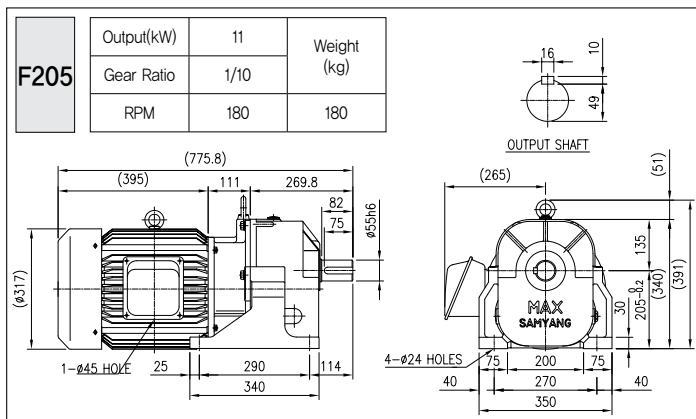
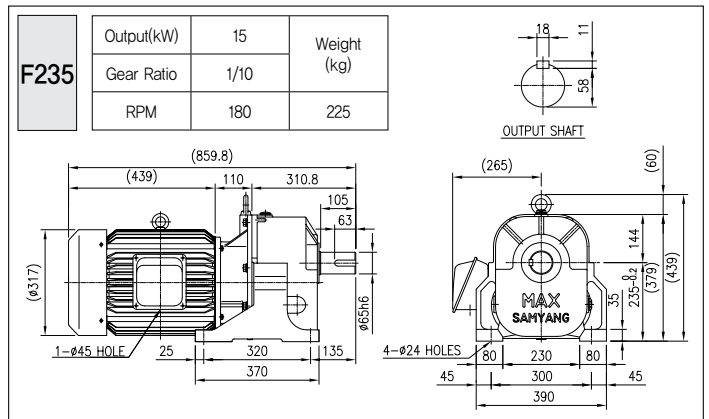
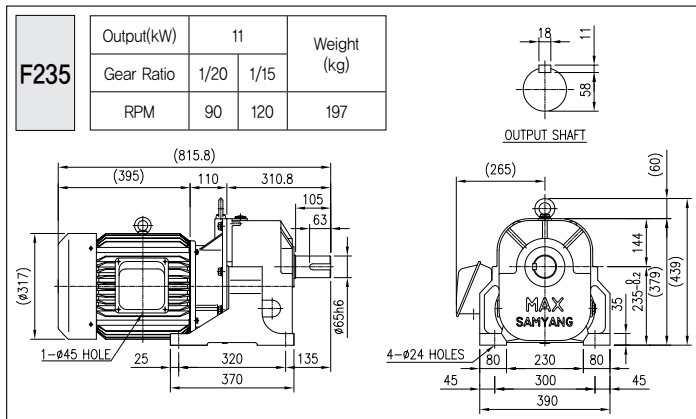
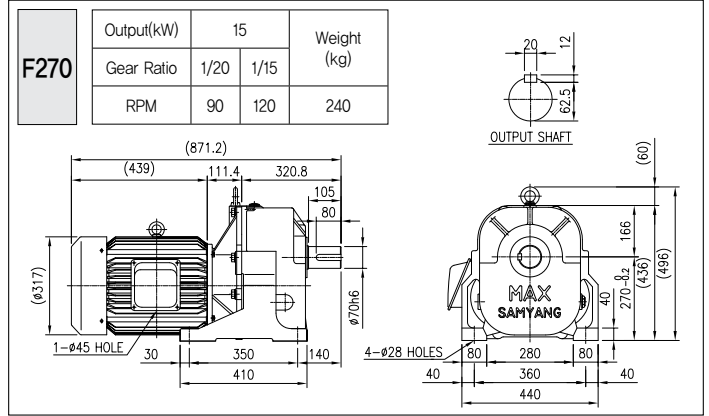

V.T GEARED MOTOR

11kW(15 HP, 3-Phase 삼상)

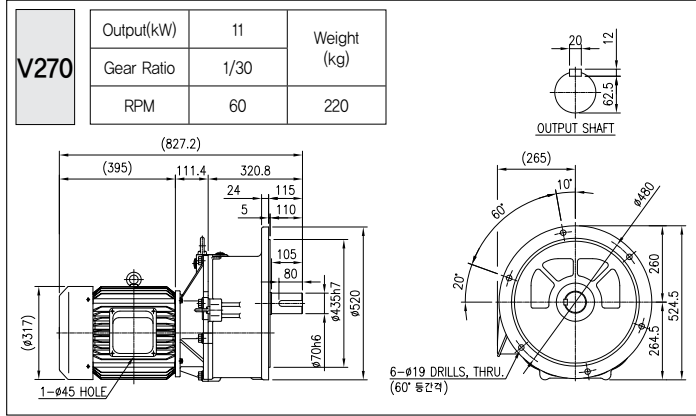

15kW(20 HP, 3-Phase 삼상)

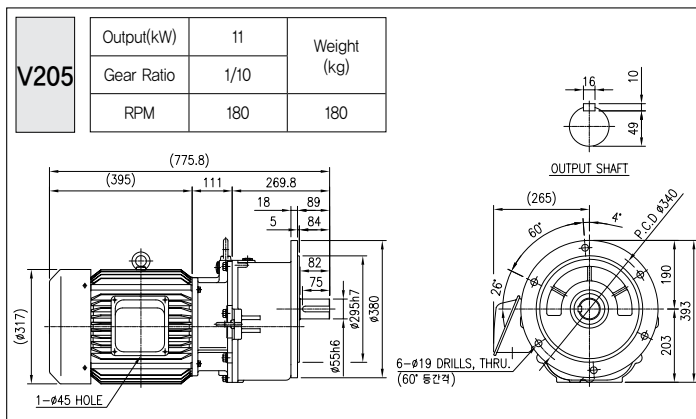
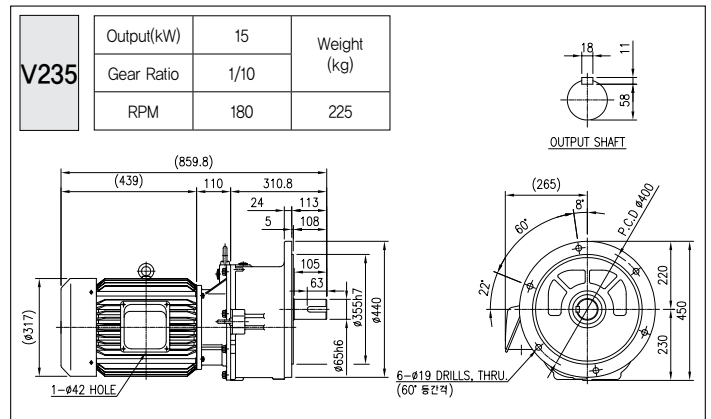
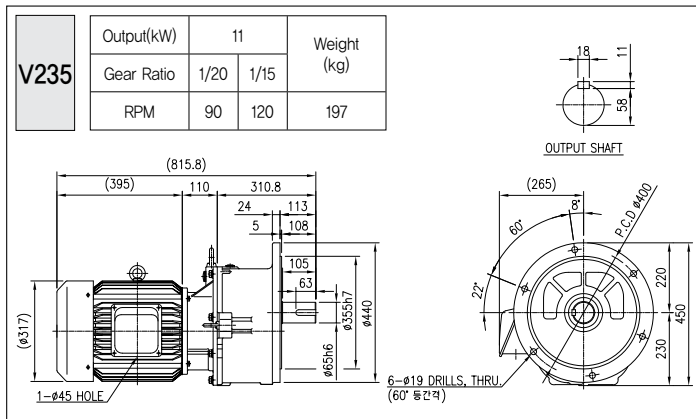
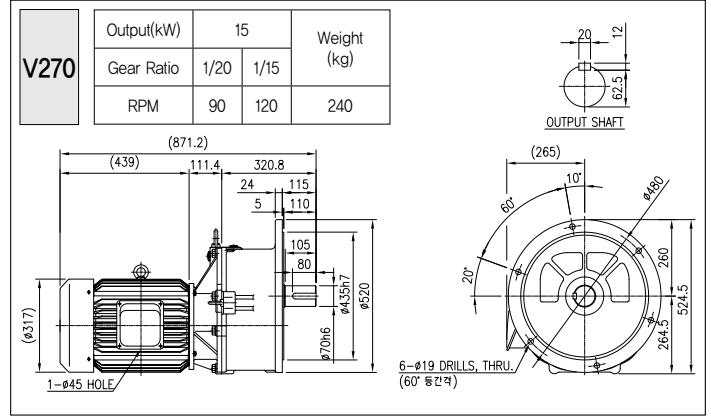

LINE POWER

11kW(15HP, 3-Phase 삼상)

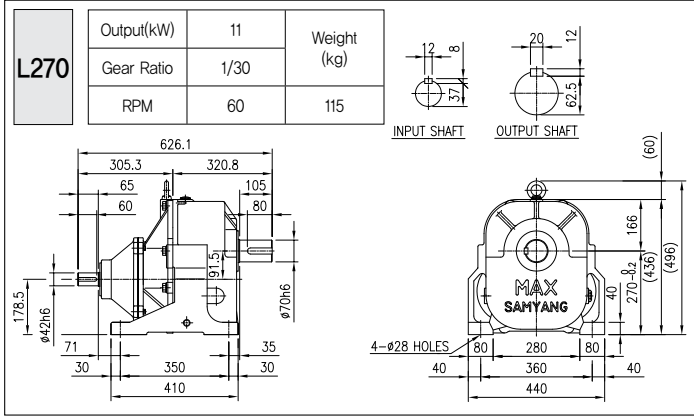

15kW(20 HP, 3-Phase 삼상)

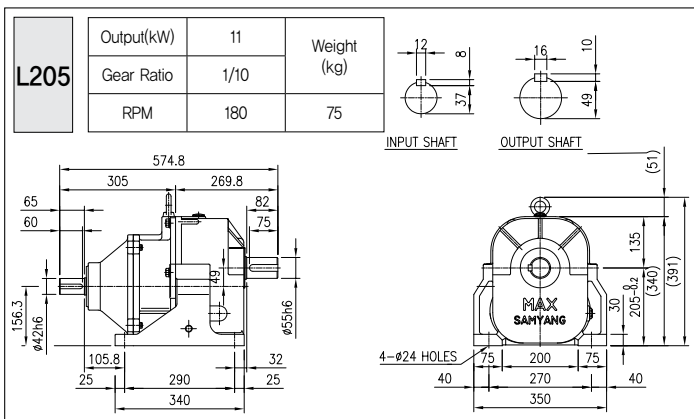
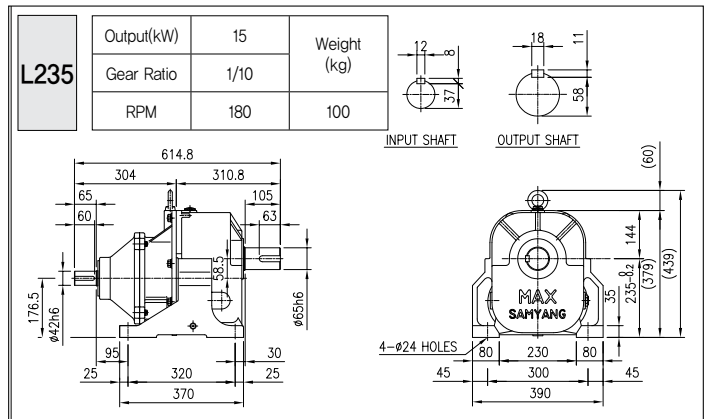
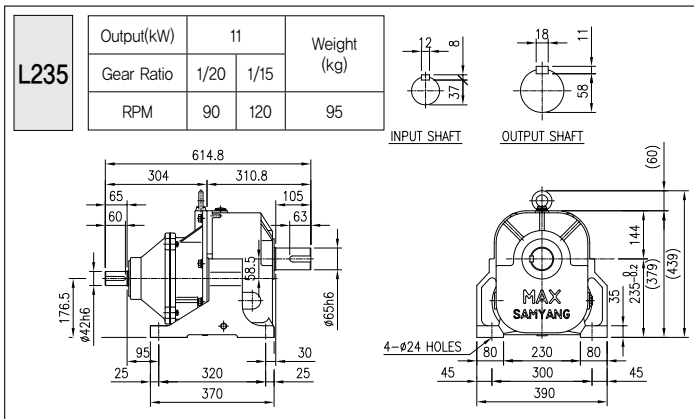
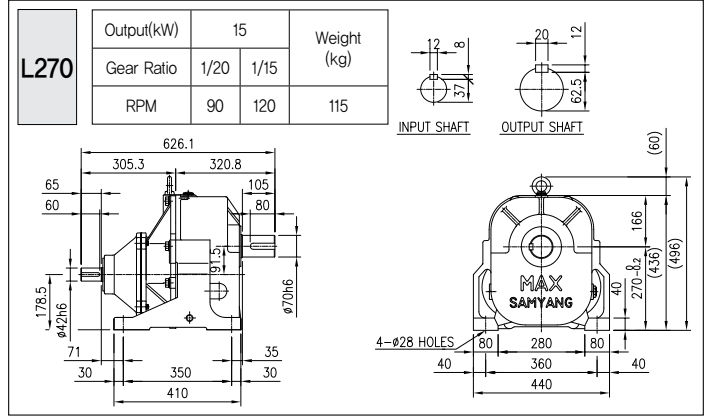

GEARED MOTOR [주차기 전용 BRAKE 부착형]

0.2kW(1/4 HP, 3-Phase 삼상)

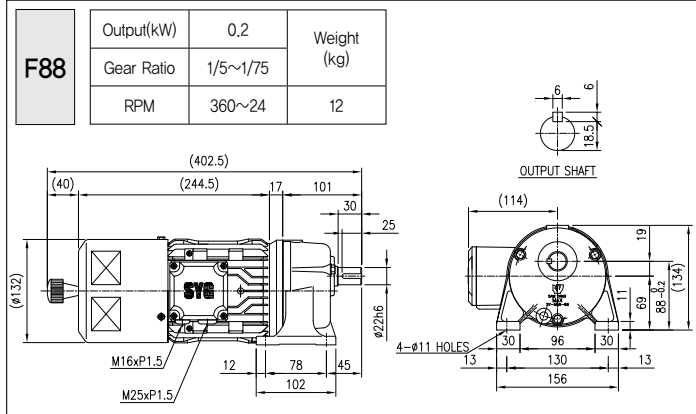

0.4kW(1/2 HP, 3-Phase 삼상)

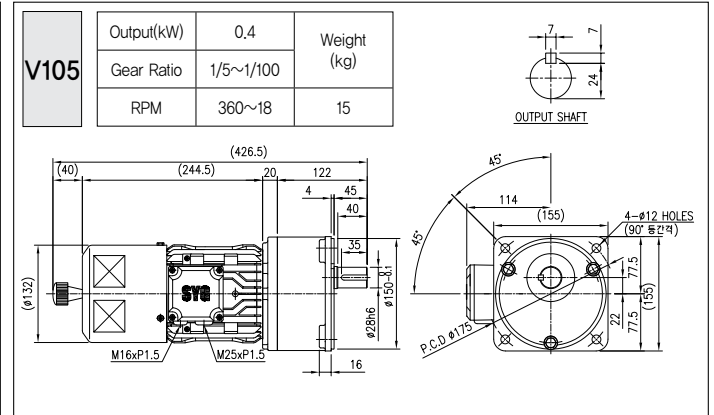
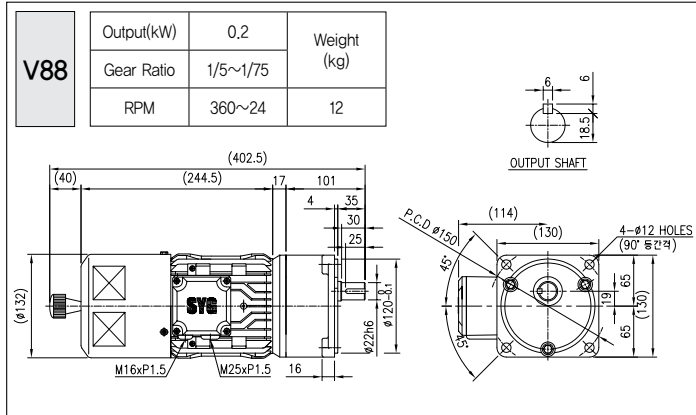
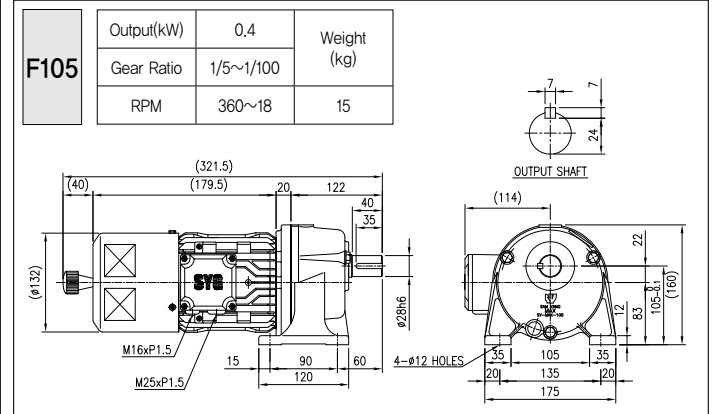

1.5kW(2 HP, 3-Phase 삼상)

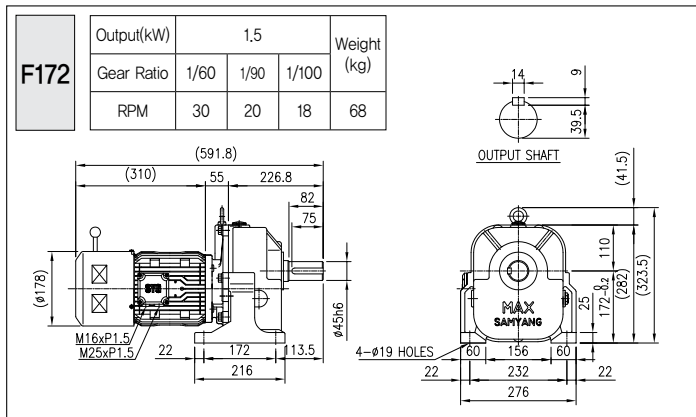

2.2kW(3 HP, 3-Phase 삼상)

